

Laminar Mixed Convection Heat Transfer Correlation for Horizontal Pipes

Myeong-Seon Chae and Bum-Jin Chung*

Department of Nuclear Engineering, Kyung Hee University

#1732 Deokyoungdae-ro, Giheung-gu, Yongin-si, Gyeonggi-do, 446-701, Korea

*Corresponding author: bjchung@khu.ac.kr

1. Introduction

Mixed convection occurs when the driving forces of both forced and natural convections are of comparable magnitude ($Gr/Re^2 \sim 1$). It is classical problem but is still an active area of research for various thermal applications such as flat plate solar collectors, nuclear reactors and heat exchangers [1].

The effect of buoyancy on heat transfer in a forced flow is varied by the direction of the buoyancy force. In a horizontal pipe the direction of the forced and buoyancy forces are perpendicular.

The studies on the mixed convections of the horizontal pipes were not investigated very much due to the lack of practical uses compared to those of vertical pipes. Even the definitions on the buoyancy coefficient that presents the relative influence of the forced and the natural convections, are different by scholars. And the proposed heat transfer correlations do not agree [2].

This study aimed at producing experimental results and developing a new heat transfer correlation based upon a semi-empirical buoyancy coefficient.

2. Previous studies

For the laminar mixed convection in a horizontal pipe, the secondary flows are formed in the thermal entrance region. They are counter-rotating vortices and they enhance the heat transfer [2]. As the flow develops, the secondary flow develops to a maximum intensity and then diminishes eventually to zero as the wall-to-bulk temperature difference decreases if the duct is long enough [3].

The force convective heat transfer in a horizontal pipe is characterized by *Graetz solution*. The Nu decreases as the dimensionless length, $X(=L/(DRePr))$ increases [4]. An *asymptote* is employed to present the natural convection limits, $Nu_a=1/2X$ [5]. In the mixed convection flows, with the addition of buoyancy effects, the average Nu becomes higher than *Graetz solution* and is lower than the *asymptote*. And then as the X increased, the Nu follows the *Graetz solution* again [6].

3. Experiments

3.1 Experimental Methodology

Mass transfer rates were measured instead of the heat transfer rates based on the analogy between heat and mass transfer. This study employed a cupric acid-copper sulfate ($H_2SO_4-CuSO_4$) electroplating system using the

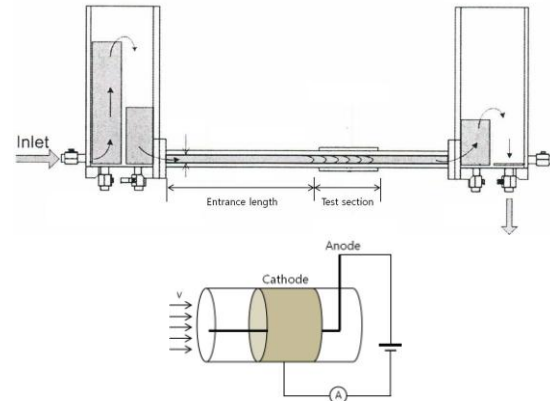

Fig. 1. The experimental equipment and circuit.

Table I: Test matrix.

Pr	$D(m)$	Ra_D	$L(m)$	L/D	Re
2094	0.026	3.0×10^9	0.03,	0.9, 1.2,	71,
			0.05,	1.6, 1.9,	141,
			0.06,	2.3, 3.1,	211,
			0.10,	3.8, 6.3,	422,
			0.20,	7.7, 9.4,	565,
	0.032	5.5×10^9	0.30,	11.5,	708,
			0.50	15.6,	844,
				19.2	112,
					1270

limiting current technique [7]. The technique is attractive, as it is simpler, cheaper, and faster than heat transfer measurement techniques. This technique has been developed by several investigators and has become a simple and accurate method of determining mass transfer rates.

3.2 Apparatus and test Matrix

Figure 1 presents the experimental equipments and circuit. Fluid flows from the upstream reservoir through the test section and then goes to downstream reservoir. In order to prevent flow perturbation, the flow rate is controlled by the head difference of upstream and downstream reservoirs and is measured by the electromagnetic flow meter. In order to achieve the fully developed velocity condition before the entrance of the test section, the flow straighteners together with the entrance length of enough length was employed. The copper cathodes are lined at the inner wall of the inside of acryl pipe and the copper inner diameter 0.026m and 0.032m. The anode copper rod was held at the center of the pipe. The copper anode rod was not affect in the wall of cathode as it was very thin (0.002m) and as the measurements are for near-cathode phenomena.

Table 1 shows the test matrix. The Pr was 2,094 and Ra_D was 3.0×10^9 and 5.5×10^9 . The length of cathodes was varied from 0.03m to 0.50m and varying the Re from 71 to 1,270 for the laminar mixed convection.

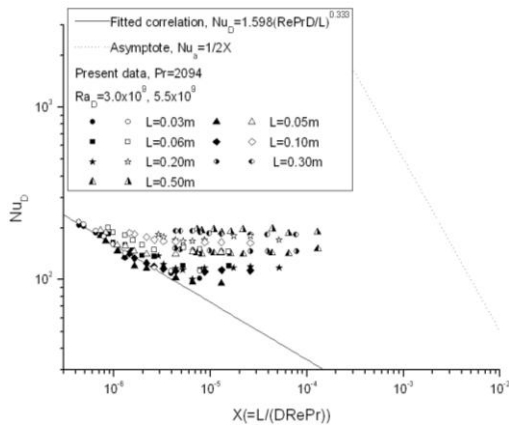

Fig. 2. The Nu_D as dimensionless length X .

4. Results and Discussion

4.1 Mixed Convection Test Results

Figure 2 shows the measured Nu_D as the X . The solid line presents the forced convection heat transfer measured with the test rig using short cathodes (0.03m), which agrees with *Graetz solution*. All data lie between the forced convection curve and the *asymptote* and they show the enhanced heat transfer due to the buoyancy.

4.2 Buoyancy Coefficient and Correlation

Yang and Yang, and Courier and Grief used Gr/Re^2 as the buoyancy coefficient and Gebhart $Gr/Re^{2.5}$ [8]. They were developed by fitting their experiments. One problem is that they don't include the length and diameter of heated pipe. The other problem is the lack of generality as the governing parameter.

The new buoyancy coefficient was derived by the Jackson approach. The natural convection correlations of Sarac and Korkut [9] and forced convection were used to account for the relative importance of Gr and Re to Nu_D . And L/D factor was included. Equation (1) shows the derived buoyancy coefficient.

$$B_o = 0.38(L/D)^{0.3} (Gr / (Re^{4/3} Pr^{1/3}))^{0.2} \quad (1)$$

The empirical correlation for laminar mixed convection was developed. The correlation not only describes the current results but also results of other works as shown in Fig. 3.

$$Nu_{mixed} = 1.598 Gz^{1/3} \left\{ 1 + 0.38(L/D)^{1.5} \left(\frac{Gr}{Re^{4/3} Pr^{1/3}} \right) \right\}^{0.27} \quad (2)$$

5. Conclusions

Mixed convection mass transfers inside horizontal pipe were investigated for the pipe of various length-to-

diameters with varying Re . Forced convection correlation was developed using a very short cathode. With the length of cathode increase and Re decrease, the heat transfer rates were enhanced and becomes higher than that of forced convection. An empirical buoyancy coefficient was derived from correlation of natural convection and forced convection with the addition of L/D . And the heat transfer correlation for laminar mixed convection was developed using the buoyancy coefficient, it describes not only current results, but also results of other studies.

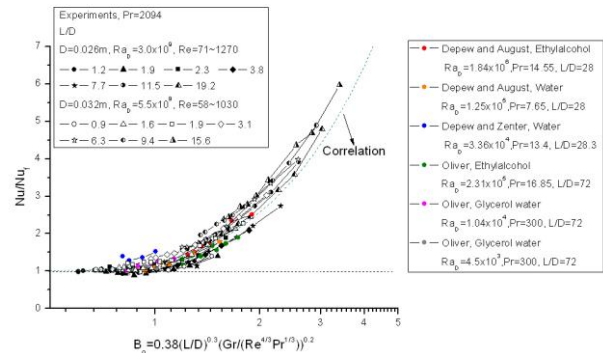

Fig. 3. The empirical correlation reflecting as B_o .

REFERENCES

- [1] T. Boufendi, M. Afrid, Three-Dimensional Conjugate Conduction-Mixed Convection with Variable Fluid Properties in a Heated Horizontal pipe, *Rev. Energ. Ren.*, Vol.8, pp.1-18, 2005.
- [2] A. R. Brown, M. A. Thomas, Combined Free and Forced Convection Heat Transfer for Laminar Flow in Horizontal tubes, *Journal Mechanical Engineering Science*, Vol.7, pp.440-448, 1965.
- [3] B. Shome, M. K. Jensen, Mixed Convection Laminar Flow and Heat transfer of Liquids in Isothermal Horizontal Circular Ducts, *International Journal of Heat and Mass Transfer*, Vol.38, pp.1945-1956, 1995.
- [4] M. Hishida, Y. Nagano, M.S. Montesclaros, Combined Forced and Free Convection in the Entrance Region of an Isothermally Heated Horizontal Pipe, *Journal of Heat and Mass Transfer*, Vol.104, pp.153-159, 1982.
- [5] B. C. Chandrasekhara, Mixed convection in the presence of horizontal impermeable surfaces in saturated porous media with variable permeability, *Warme-und Stoffubertragung*, Vol.19, pp.195-201, 1985.
- [6] J. W. Ou, K. C. Cheng, NATURAL CONVECTION EFFECTS ON GRAETZ PROBLEM IN HORIZONTAL ISOTHERMAL TUBES, *International Journal of Heat and Mass Transfer*, Vol.20, pp.953-960, 1977.
- [7] J. R. Selman, C. W. Tobias, Advances in chemical engineering-Mass Transfer Measurement by the Limiting Current Technique, *ELSEVIER*, Vol.10, pp.211-318, 1978.
- [8] J. P. Coutier, R. Greif, An investigation of laminar mixed convection inside a horizontal tube with isothermal wall conditions, *International Journal of Heat and Mass Transfer*, Vol. 28, pp. 1293-1305, 1985.
- [9] H. Sarac, O. Korkut, External and Internal Natural Convection Mass Transfer at Cylindrical Tubular Electrodes, *Journal of Chemical Engineering of Japan*, Vol.32, pp.130-133, 1999.