

# Laser Ultrasonic Testing System for Remote Inspection

Sung-Hoon Baik <sup>a</sup>, Seung-Kyu Park <sup>a</sup>, Min-Suk Kim <sup>a</sup>, Chang-Hwan Lim <sup>a</sup>

<sup>a</sup> Laboratory for Quantum Optics, KAERI, Dukjin-Dong 150, Yusong, Daejeon 305-353, Rep. of Korea  
shbaik@kaeri.re.kr

## 1. Introduction

The ultrasonic testing method has been used in the fields of Non-Destructive Testing (NDT) for many decades. The conventional transducers are mainly used to generate and detect an ultrasonic signal. But in the case of a specimen with a complex geometry and a narrow space, it is difficult to detect cracks by using the ultrasonic inspection method using conventional transducers. And the contacting transducer method can not be applied to the inspection of some irradiated structures, such as nuclear reactor pressured vessels and internals. The laser ultrasonic method that uses laser beams for the generation and detection of an ultrasonic signal is applicable to the inspection of these parts since it is inherently a non-contact inspection method and broadband. Nowadays laser ultrasonic testing is a widely used non-destructive inspection technique for many industrial fields [1].

The laser ultrasonic techniques consist of a pulsed laser for an ultrasonic wave generation and a laser interferometer for the detection of an ultrasonic signal. There are many kinds of interferometers to detect an ultrasonic signal, such as the Michelson or Mach-Zehnder interferometer [2], Fiber-optic interferometer [3], Wave-mixing interferometer [4], Confocal Fabry-Perot interferometer [5-7], etc.. In many industrial applications, a sample surface may not be optically flat and some environmental vibrations can exist. In these industrial applications, a confocal Fabry-Perot interferometer is more useful than other plane interferometers because the confocal interferometer can receive many speckles scattered over a wide angle.

## 2. Instrumentation and Experiments

In this section a laser ultrasonic system that consists of a pulsed Nd:YAG laser, a CW frequency stabilized laser and a confocal Fabry-Perot interferometer, was described. The performance of the system and the experimental results of the laser ultrasonic system are described in this section.

### 2.1 Optical System

The optical arrangement of the confocal Fabry-Perot interferometer is shown in Figure 1. A frequency-doubled pulsed Nd:YAG laser (Model CFR200, Big-Sky Laser) was used to generate an ultrasonic wave in a sample. The pulse output energy of the laser is 100 mJ and the pulsed duration of the Q-switched pulse is about 10 ns. The Confocal Fabry-Perot interferometer

(Burleigh CFT-500) is used for detection of the ultrasonic signal. Free Spectral Range (FSR) is 150 MHz and finesse is about 100. A CW frequency stabilized DPSSL Green laser (Lightwave Model 142) with an output power of 200 mW was used as a detection laser.

The transmitted intensity of the CW laser beam shows a Fabry-Perot resonance curve that has a narrow peak. The surface vibration due to an ultrasonic wave causes a Doppler shift of the frequency of the CW laser. The frequency-shift of the CW laser modulates the transmittance and reflectance of the laser beam, in which the information of the ultrasonic waves is contained. The transmitted and reflected CW laser beam was measured by a high-speed avalanche photodiode (Model C30902E, Perkin Elmer) with an amplifier. The bandwidth of the photodiode is 100 MHz. The photodiode signals were recorded by a multi-channel digital storage oscilloscopes (Tektronics TDS 684A).

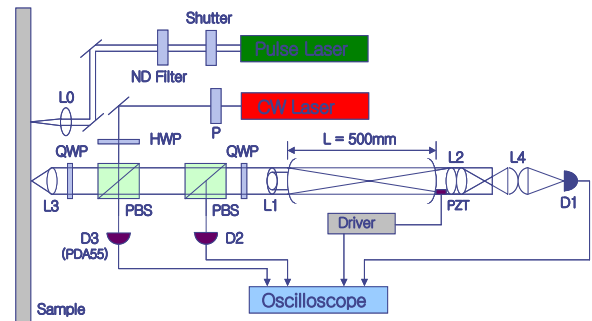

Figure 1. Schematic diagram of the Laser Ultrasonic system using a Confocal Fabry-Perot interferometer

### 2.2 Fringe Stabilizer system

The transmitted fringe pattern of the interferometer is unstable because of some environmental noise such as a thermal drift, vibration, etc.. In order to obtain a stable ultrasonic signal, a fringe stabilization system is needed[8]. We have developed a fringe stabilizer module for the Confocal Fabry-Perot interferometer. The fringe stabilizer module is an active control system based on the feedback control using PZT. The stabilizer module controls the PZT voltage so that the transmittance of the CW DPSSL laser beam remains at an optimum point. Figure 2 shows the flow chart of the fringe stabilizer to closed-loop control the optimum PZT voltage.

### 3. Conclusion

In this research, a laser ultrasonic system is implemented. The laser ultrasonic system consisted of a pulsed Nd:YAG laser of 100 mJ output for an ultrasonic wave generation and a CW DPSSL laser of 200 mW output power combined with a confocal Fabry-Perot interferometer and an adaptive fringe stabilizer for the detection of the wave. Using the confocal Fabry-Perot interferometer system, some laser ultrasonic experiments were carried out in order to test the performance of the system. Laser generation and laser detection of surface/longitudinal waves are investigated by using the interferometer system. These measurements were compared to the experimental results by using a contacting transducer

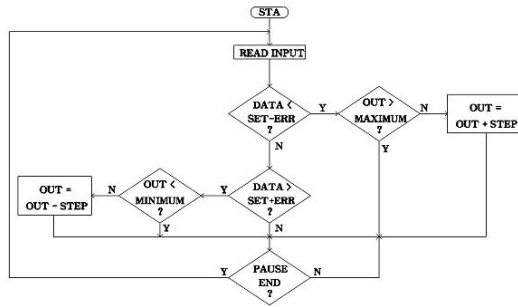

Figure 2. Flow chart of the fringe stabilizer for the Confocal interferometer

### 2.3 Experimental results

To test the performance of the laser ultrasonic system with a fringe stabilizer, some experiments were carried out. Figure 3 and Figure 4 show waveforms of the ultrasonic signal obtained by a transducer(5MHz) with an amplifier and laser-induced ultrasonic signal measured by the interferometer, respectively. A carbon steel plate of 15 mm thickness was used as a specimen. From the figures, it was shown that the frequency of the laser-induced ultrasonic signal is higher and broader than that from transducer. The high frequency and broadband characteristics of laser ultrasonic testing can be used to inspect micro-cracks in metallic component.

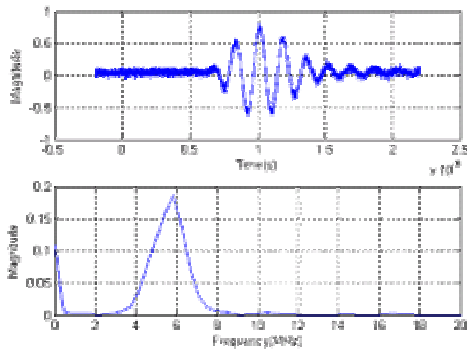

Figure 3. Ultrasonic signal obtained by a transducer and Frequency spectrum of the signal.

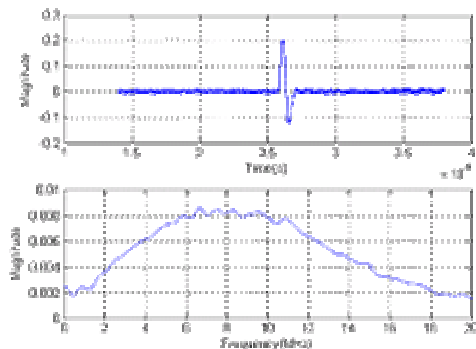

Figure 4. Ultrasonic signal obtained by laser ultrasonic system and Frequency spectrum of the signal.

### REFERENCES

- [1] C.B Scruby, L.E. Drain, Laser Ultrasonics: Techniques and Applications, Adam Hilger, Bristol, 1990.
- [2] T. Miura, M. Schiai, H. Kuroda, S. Soramoto, S. Kanemoto, laser-induced surface wave testing : A new method for measuring the depth of cracks, 9<sup>th</sup> international conference on nuclear Engineering (ICONE-9), Nice, April 2001, Paper No. 312.
- [3] B. Mitra, S. Shelamoff, D.J. Booth, An optical fibre interferometer for remote detection of laser generated ultrasonics, Measurement Science and Technology, Vol. 9, 1432-1436, 1998
- [4] J. -P. monchalain, Application of wave mixing in photorefractive materials to laser ultrasonics, Lasers and Electro-Optics, 1998, CLEO 98, Summaries of papers presented at the Conference on, 1998, p. 528-529
- [5] J. -P. Monchalain, R. Heon, Broadband optical detection of ultra-sound by optical sideband stripping with a confocal Fabry-Perot, Applied Physics Letters, Vol. 66, 1612-1614, 1989
- [6] R.J. Dewhurst, Q. Shan, Modeling of confocal Fabry-Perot interferometers for the measurement of ultrasound, Measurement Science and Technology, Vol. 5, 655-662, 1994
- [7] Takao Tanaka, Yasukazu Izawa, Nondestructive detection of small internal defects in carbon steel by laser ultrasonics, Japaness Journal of Applied Physics, Vol. 40, 1477-1481, 2001
- [8] J.F. Dorigi, S. Krishnaswamy, J.D. Achenbach, Stabilization of an embedded fiber optic Fabry-Perot sensor for ultrasound detection, IEEE Transactions of Ultrasonic, Ferroelectrics, and Frequency control, Vol. 42, 820-824, 1995