

Proceedings of the Korean Nuclear Spring Meeting  
Gyeongju, Korea, May 2003

## The Enhancement of the Ultrasonic Images by a Special Signal Processing for Side Drilled Holes of the NPPs S/G Material and Multi-layers Inner- Gaps

Kil-Mo Koo\*, Sang-Baik Kim\*, Young-Mu Jeong\* Hee-Young Kang\*,

KAERI  
150 Dukjindang, Yuseong  
Daejeon, Korea 305-353

### Abstract

In this paper, we have studied the images which have been reconstructed by using combination of images acquired by the variation of operating frequency. When inner images have been reconstructed, they have been superposed by the surface state effect. In this case, the images of the phase object can be enhanced by the contrast of inner images. In this experiment, there are two kinds of specimens, one is a reference block having 1/4T, 1/2T, 3/4T each side drilled holes as main run piping material of the steam generator in NPPs and the another is a part of a hemisphere type specimen having about 1-2 mm distance gap. It has been shown that the two results of defect shapes have better than before in this processing and phase contrast grow about twice. And we have constructed the acoustic microscope by using special signal processing ; a quadrature detector that enables to acquire the amplitude and phase of the reflected signal simultaneously. Further more we have studied the reconstruction method of the amplitude and phase images and the enhancement method of the defect images' contrast.

### 1. Introduction

In this paper, we have built a scanning acoustic microscope(SAM) operating in the 3 to 5 MHz range using quadrature detector that measures both amplitude and phase. It has been primarily used in non-destructive(NDE) of machined parts, composite materials, etc for the presence of cracks. Most SAMs measure amplitude only using envelope detector. By measuring phase as well, we can carry out quantitative NDE and image processing that can be done with amplitude or phase alone. We have demonstrated image processing applications that use amplitude and phase measurement; such as transducer characterization, material

reflectance function measurements using  $V(z)$  inversion. We have been studied the reconstructive method for the enhancement of depth resolution for acoustic image using variation of the frequency. In this experiment, we have constructed the SAM system by 5 MHz central frequency and 35% fractional bandwidth. There are two kinds of specimens, one sample is a reference block to have 1/4T, 1/2T, 3/4T side drilled hole as main run piping material of the steam generator and another one is a part hemisphere to have about 1-2 mm distance gap. The side drill holed sample 2, reference block which is made in stainless steel as a material of the nuclear power plants. The enhanced depth resolution has been applied to measure the profile of trench. We operated in the 4.4 MHz to 5.6 MHz range that measures both amplitude and phase reliably and accurately. In this experimental result, we have been found that image using variation of the operating frequency was better than image using single operating frequency. Even better depth resolution can be obtained by numerically combining images taken at several different frequencies. The resulting images have a greater range of coverage in the spatial frequency domain in the depth direction than does a single frequency image. Increased depth resolution can be obtained by taking three-dimensional images at more than one frequency and numerically combining the results.

In order to enhance depth resolution, we have reconstructed the image using the image acquired with multi operating frequency for acoustic microscope. This method has been able to increase the variation of the image intensity of amplitude image by comparison that with single frequency. And this method has been complement that the phase image has the limitation whose the operating range has been  $\pi$ .

It is also possible to improve the depth resolution of a low aperture microscope. So it is as good as with a wide aperture system. This could be very useful for imaging objects with high relief, where the use of a wide aperture lens could degrade the images of deep features.

## 2. Enhancement of Depth Resolution for Acoustic Image using the Spatial Frequency Response

Generally, the resolution of the SAM has been decided by the performance of the ultrasonic transducer[1-4]. Therefore, the quality of image to be acquire from the SAM system was determined according to the operational frequency and the acoustic lens. Conventional SAM was operated at center frequency of an acoustic transducer's fractional bandwidth to reconstruct acoustic image.

Not only does a SAM have good lateral resolution, it also good depth resolution. The fact that the  $V(z)$  curve falls off so rapidly as the transducer is defocused is evidence of good depth resolution. When the transducer is on focus, the wave fronts of the acoustic waves reflected from the surface coincide with the transducer face and give a large return signal. As the transducer is defocused the wave fronts are not aligned with the transducer face and

cancellation occurs. And the percentage increase in depth resolution actually is much better than for the transverse resolution. To look at smaller objects, the wavelength must be reduced by using a high frequency acoustic microscope or a confocal scanning optical microscope(CSOM) that measures amplitude and phase[5][6].

## 2.1 Theory

The resolution enhancement technique is most easily visualized in the spatial frequency domain. The maximum depth resolution that can be obtained is determined by the range of special frequencies that are covered by the microscope spatial frequency response (SFR). Recall that this range is called the base of support of the SFR. An object's spectrum outside this region is not measured by the microscope. This range of spatial frequencies limits the resolution that can be obtained. The top edge of the SFR corresponds to the circle separating propagating and evanescent waves [6].

The bottom edge is determined by the f-number of the transducer. If the transducer is operated at a different frequency, the base of support is shifted in the  $k_z$  direction. Figure 1 shows the based of support for a microscope operating at two different frequencies superimposed. The images formed by operating the microscope at different frequencies can be combined to cover a broader range of spatial frequencies along the  $k_z$  dimension. When the acoustic transducer is shaped like a cylinder and symmetric, the SAM has a region, where figure 1 shows, because transducer is used both transmitter and receiver, where the spatial frequency is equation (1).

$$|k| = \sqrt{k_x^2 + k_y^2 + k_z^2} \quad (1)$$

Transverse frequency is defined like equation (2) in direction of transverse.

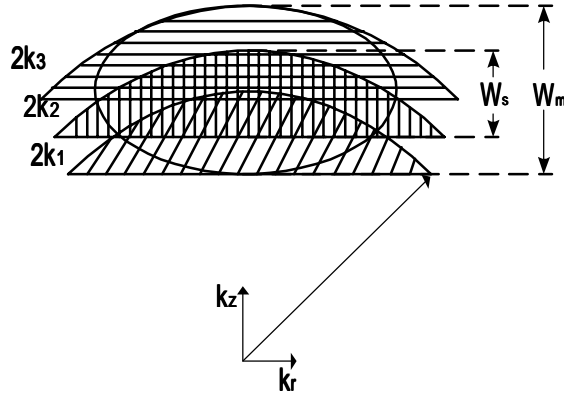
$$|k_r| = \sqrt{k_x^2 + k_y^2} \quad (2)$$

If the resolution of transverse is defined, the depth resolution is decided as equation (3).

$$k_z = \sqrt{k^2 - k_r^2} \quad (3)$$

The method that was used for enhancing images can be got by combining images which were taken operating at different frequencies within bandwidth of acoustic transducer in SAM. Image spectrum that was obtained at any single operating frequency is equation (4).

$$G(w_i; \vec{k}) = H(w_i; \vec{k}) F(\vec{k}) \quad (4)$$



**Fig. 1** Bases of support for the microscope's spatial frequency response at 3 different frequencies superimposed

For each spatial frequency  $k$ , equation (4) can be viewed as a matrix equation relating the object to the measured images and spatial frequency of objects like equation (5) where equation (5) is indexed by  $w_i$ .

$$\begin{bmatrix} G(w_1; \vec{k}) \\ \cdot \\ G(w_N; \vec{k}) \end{bmatrix} = \begin{bmatrix} H(w_1; \vec{k}) \\ \cdot \\ G(w_N; \vec{k}) \end{bmatrix} [F(\vec{k})] \quad (5)$$

In matrix notation, equation (5) is equation (6).

$$G_{\vec{k}} = H_{\vec{k}} F_{\vec{k}} \quad (6)$$

Equation (6) can be solved using the method of least square to get equation (7).  $F_{\vec{k}}$  is the result which is a best approximation to the objects as computed from the method combining images taken at multi-frequencies.

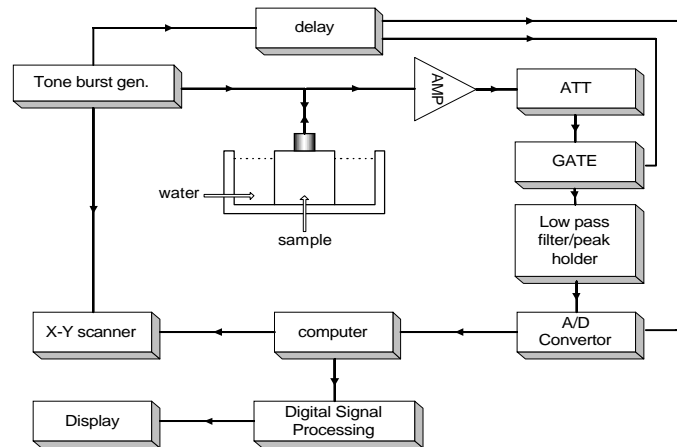
$$F_{\vec{k}} = \frac{H_{\vec{k}}^u G_{\vec{k}}}{H_{\vec{k}}^u H_{\vec{k}}} \quad (7)$$

Where  $H_{\vec{k}}^u$  means inverse matrix of original transducer spatial frequency response matrix.

### 3. Experiments and Considerations

In nuclear power plants, it is important that we can detect a defect like a presence of cracks,

voids, and delaminations in the NPPs' materials. So, we prepare to two kinds of materials as the same material. And we have built a scanning acoustic microscope operating in the 0.5 MHz 4 MHz range. Figure 2 shows a block diagram of the scanning acoustic microscope. As a result, we can get good signal noise ratio for the 2 types samples. And lower frequency was used to obtain the depth's penetration.

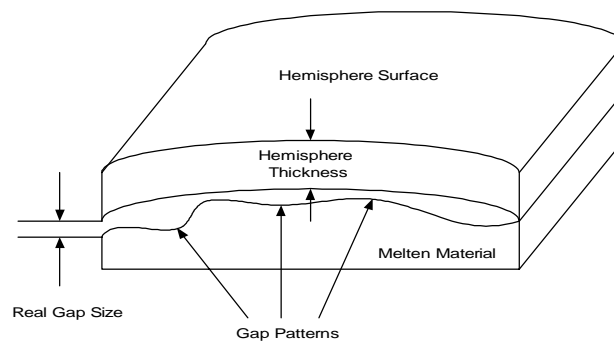


**Fig. 2** Blocks diagram of the scanning acoustic microscope.

### 3.1 Sample Preparation

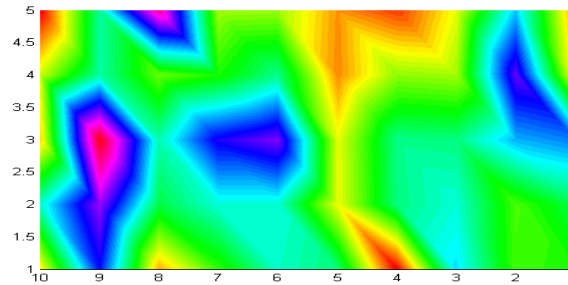
One sample, reference block to have 1/4T, 1/2T, 3/4T, has side drilled defects with 4.6 mm inner diameter and  $T = 67.5 \mu\text{m}$  thickness and another one is a part hemisphere type specimen to have about 1-2 mm distance gap. In the result of line scanning for the sample 2 with each side drilled defects, it has been shown that the variation rate of amplitude image intensity and the variation rate of phase image intensity.

#### 3.1.1 Sample 1(a part hemisphere type specimen)

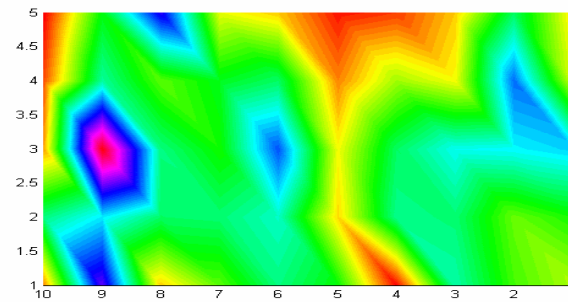


**Fig. 3** A schematic of a sample 1.

Two classes put together like Figure 3. Following figure 4 and 5 are results. They are very similar because we scanned very rough. But we found little enhanced resolution(color contrast) at gap distance distribution in data using multi-frequencies figure 5 than a single frequency figure 4. As results, the color contour was scaled up the gap distance distribution of the figure 5 than the figure 4



**Fig. 4** Internal image reconstructed with a single frequency



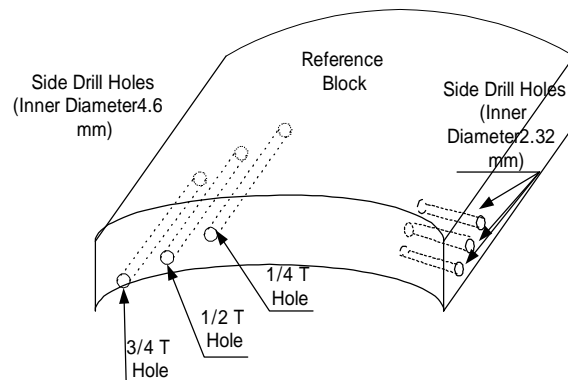
**Fig. 5** Internal image reconstructed with multi-frequencies

To obtain internal image, which we wanted, reflected signal was filtered by rectangular window. and then mixed Filtered signal and reference signal. After this, output signal passed LPF(low pass filter).

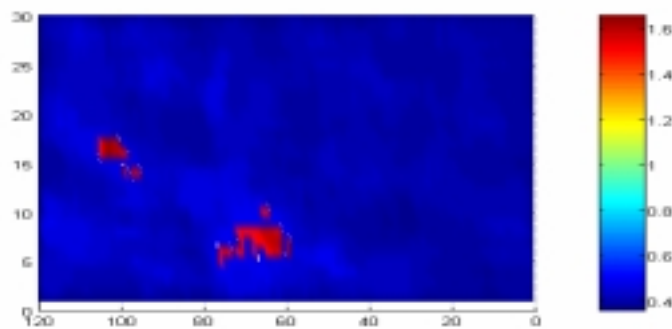
### 3.2.2 Sample 2 (Reference block)

Sample 2, reference block, has three holes at different depth in each sectional plans of the sample like figure 6. Figure 6 shows a schematic of a sample 2 as a reference block. Each inner diameters of holes are 4.5mm in each sectional plans. We can detect two side-drilled holes of three at one plan. We go through the same process as sample 1 do. Following figure 7 and 8 are sectional images reconstructed with a single frequency and multi-frequencies. We

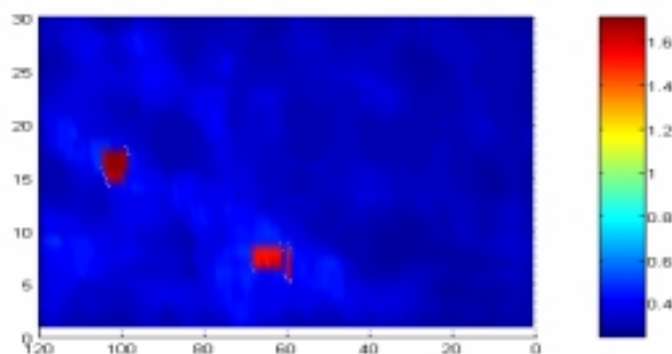
can get little reducing noise that is generated by scattering at edge of hole. And we can found a hole position accurately. Next two figures are mesh images for figure 5 and 6. So, they represent reducing noise and getting better depth resolution when sectional image is reconstructed by operating SAM with multi-frequencies



**Fig. 6** A schematic of a sample 2 (Reference Block).



**Fig. 7** Sectional image reconstructed with a single frequency



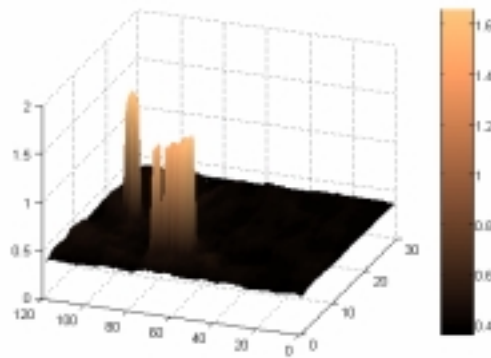
**Fig. 8** Sectional image reconstructed with multi-frequencies

Better depth resolution can be obtained by numerically combining images taken at several different frequencies in fractional bandwidth of transducer. The resulting images have a greater range of coverage in the spatial frequency domain in the depth direction than does a single frequency image. Improved depth resolution can be obtained by taking three-dimensional images at more than one frequency and numerically combining the results.

#### 4. Results

In this paper, we have studied the method for enhanced depth resolution of acoustic image. Up to now, SAM was operated at single frequency. But when SAM is operated at multi-frequencies, spatial frequency response region of SAM is widened. Because bases of support for the microscope' spatial frequency response operating at each frequency are delayed in spatial frequency domain. So enhanced depth resolution can be obtained by combining images taken at more than one frequency.

In sample 1, we can find the gap distribution from a part of a hemisphere type specimen, which is in the sample, using enhancing method. When imaging at an internal plane, we have moved the transducer closer to the sample in order to concentrate more acoustic energy on the below of the surface of sample. In this case, the internal image has the superposition of surface image characterization.



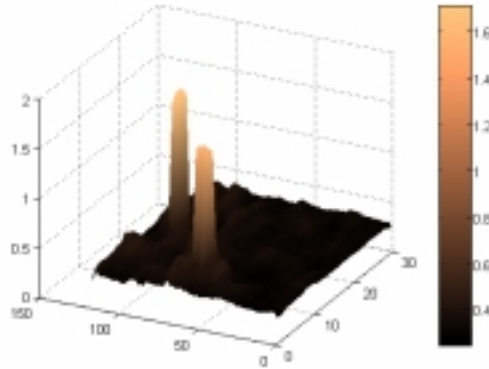
**Fig. 9** Sectional image reconstructed with a single frequency

With both amplitude and phase information, it is possible to remove the surface effect by taking an image with the transducer focused on the surface. From the result of this technique, we have obtained enhanced internal images which has better contrast than the image acquired by the conventional method.

In sample 2, we can reduce noises that are generated by scattering at edge of side drilled holes, and we can find a hole position accurately. They represent reducing noises and getting



better depth resolution when sectional image is reconstructed by SAM operated with multi-frequencies



**Fig. 10** Sectional image reconstructed with multi-frequencies

From this experimental result, a better depth resolution can be obtained by numerically combining images taken at several different frequencies in fractional bandwidth of transducer. The resulting images have a greater range of coverage in the spatial frequency domain in the depth direction than does a single frequency image. A more improved depth resolution can be obtained by taking three-dimensional images than by one frequency and numerically combining the results.

It is also possible to improve the depth resolution of a low aperture microscope. So it is as good as with high relief, where the use of a wide aperture lens could degrade the images of deep features.

#### ACKNOWLEDGEMENT

This study has been carried out under the nuclear R&D program by the Korean Ministry of Science and Technology.

#### Reference

- (1) A. Briggs, 1992, "Acoustic Microscopy", Oxford.
- (2) P.A. Reinholdtsen, 1989, "Image processing for an amplitude and phase acoustic microscope" a dissertation submitted to the department of applied physics and the committee on graduate studies of Stanford university in partial fulfillment of the requirements for the degree of the doctor of philosophy.
- (3) D. S. Ko, 1991, "Composition and performance analysis for the small aperture type ultrasonic acoustic microscope systems", a thesis for Ph. D. degree of Kyung Hee university .
- (4) Hobbs, P. C. D., August 1987, Rev. Sci. Inst. 58, 8.

- (5) G.S.Kino, "Acoustic waves : devices, imaging and analog signal processing", PRENTICE-HALL
- (6) P.Reinholdtsen., 1986, "Remove the effects of surface in acoustic microscopy", IEEE. Ultrasonic Symposium, pp.756~763
- (7) Auld, B. A., 1973, "Acoustic fields and waves in solids", NY: Wiley.
- (8) Philip Denbigh, "System analysis & signal Processing", Addison-Wesley
- (9) Jae S. Lim, 1990, "Two-dimension Signal and image processing", Prentice-Hall.
- (11) J. Krautkramer, 1990, " Ultrasonic Testing of Materials ", Springer-Verlag Press
- (12) Digital Signal Acquisition & Processing for NDE & Plant Maintenance Workshop, Jul 31-Aug 3, 1990, Sponsored by EPRI & Hosted by the EPRI NDE Center.