

## Debris Filtering Test Procedure for PWR Fuels and a Series of Tests Results

Ki-Wan Park<sup>a\*</sup>, Nam-Gyu Park<sup>a</sup>, Jae-Ik Kim<sup>a</sup>

<sup>a</sup>R&D Center, KEPCO Nuclear Fuel., 242 Daedeok-daero 989 beon-gil, Yuseong-gu, Daejeon, Korea

\*Corresponding author: kiwan@knfc.co.kr

### 1. Introduction

Debris is one of main fuel failure mechanism in Korean plants, and is likely to become the leading PWR fuel failure mechanism within the EPRI(Electric Power Research Institute) membership in the future. Fuel rod cladding failures (leaking fuel rods) can be caused by debris trapped in a grid region which vibrates against the fuel rod cladding.

In the worldwide fuel failure causes occurring in PWRs from the year 2006 to 2010, the percentage of the grid-to-rod fretting wear-induced fuel failure is about 40% and that of the debris-induced fuel failure is about 13% [1]. In addition, it is reported that the percentage of the debris-induced fuel failure covers more than 35% for BWRs. Since debris is produced during nuclear power plant construction or overhaul period, types of debris may be dependent upon plant environment and systems. Debris that can generate the fuel failure is mostly metals having various shapes. Nuclear fuel vendors have their own test facilities for evaluating debris-filtering efficiency of nuclear fuels but every fuel vendor may seem to employ its own debris types for debris-filtering tests. In addition, its test method along with its test facility is different one another.

To protect fuels from debris, fuel vendors including KEPCO NF (KEPCO Nuclear Fuel) provide the fuel with debris filtering capacity. During the fuel development process, debris filtering test is usually performed for filtering efficiency measurement. This paper will introduce the currently developed debris filtering test method and discuss some test results.

### 2. Test Configuration & Procedure

#### 2.1 Overview of the Test Loop

The test facility consists of a transparent test housing, a debris insert valve, a pump, water tank, and flow velocity controller. P&ID of the facility is shown in Fig. 1. Strainers are attached before the pump inlet and after the flow housing to collect debris. The fuel assembly housing can accommodate a full size grid, and the fuel usually consists of one bottom nozzle, one bottom grid including protective grid, and one mid grid. Since debris must be blocked below protective grid, the test mock-up is quite reasonably assembled to review the debris blocking and trapping ability.

The flow housing is a structure for simulating the reactor core structure in which nuclear fuel assemblies are loaded and has a capability of supplying the coolant

after fuel loading. In addition, the housing is to be made of transparent materials to identify debris capture locations during the operation after debris is put into. If the housing is not made of transparent materials, it is difficult to identify initial locations of debris captured since debris captured is dropped after the operation completion and furthermore the possible release of debris from the test fuel assembly may have an influence on the evaluation of the debris-filtering efficiency.

The nuclear fuel assemblies loaded in the reactor core should maintain their distance. Accordingly, the housing should have the simulated lower internal structure and its size should allow one fuel assembly or a few fuel assemblies. The housing containing one fuel assembly specimen smaller than the actual fuel assembly loaded in the reactor core may not be useful for evaluating precisely the debris-filtering performance of the bottom nozzle and protective grid. Therefore, the housing in which more than one fuel assembly can be loaded is needed since its geometrical structure different from that of the reactor core can change the coolant-induced debris influx path. For the housing containing one fuel assembly, the gap length and width between the fuel assembly and the housing is to be the same as those between the adjoining fuel assemblies loaded in the reactor core to secure the coolant paths in the debris test loop similar to those in the reactor core on the one hand and to simulate the effect of the gap between adjoining fuel assemblies on the other hand.

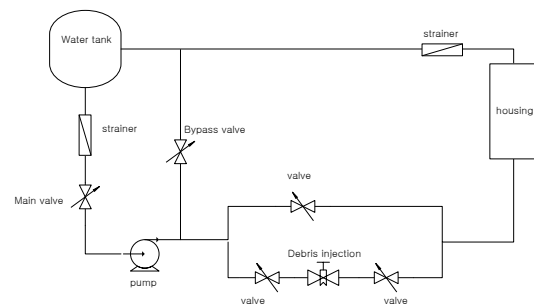

Fig. 1 P&ID of the test loop

#### 2.2 Test Procedure

The coolant supplied by the pump is to be warmed-up prior to the debris insertion and to be operated stably. The coolant stabilized time is dependent on the pump capacity and the debris-filtering test is to be carried out after circulating the coolant through the entire loop at least more than one hundred times at a rated operation

speed (coolant supply speed). If the entire loop length is 15 m and the coolant speed at the main pipe is 3 m/s, the debris-filtering test is to be performed after 500 seconds elapsed from the pump startup. In addition, if the coolant speed at the main pipe is so fast that it takes less than 500 seconds for the coolant to circulate one hundred times, the preheating operation is to be carried out at least longer than five minutes. For the stabilized coolant operation, the steady-state flow speed condition should be taken into account by removing air sufficiently with the bypass line opening.

The aforementioned pre-operation time is a requirement for the minimum time needed to operate normally all sorts of equipment such as the pump and it may change in accordance with the equipment characteristics. On the other hand, it is difficult to attain the steady-state operation condition during the debris insertion since various valves around the insertion entrance are open or closed simultaneously.

The adequate number of debris inserted for the debris-filtering test is to be determined. The large number of debris inserted may generate interference between debris, while the small number of debris inserted may cause some difficulty in obtaining a reliable result since repetitive debris-filtering tests usually generate a wide range of debris-filtering efficiency. In order to determine the adequate number of debris inserted, the respective debris-filtering tests employing the different number of debris inserted are to be carried out with identical shapes of debris and subsequently a relevant statistical analysis is to be done and the interference between debris is to be examined. The number of debris inserted can be increased when the interference between debris does not occur and vice versa.

### 3. Test Results

Since debris is produced during nuclear power plant construction or overhaul period, types of debris may be dependent upon plant environment and systems. Debris that can generate the fuel failure is mostly metals having various shapes. Metal wires are usually found in the reactor core, and the wear mark in the leaked fuel frequently resembles wire. Thus, lots of wire debris are manufactured. In addition, the wire debris is more useful to decide debris filtering efficiency comparing to the thin plate. Fig.2 show the result of debris filtering test with wires and plates. It is clearly shown that the filtering performance can be critically determined with the wire debris.

To review any difference depending on the number of debris injected, one-way ANOVA was introduced. The wire debris with 2 mm diameter and 10 mm length is prepared. The number of debris injected at the same time is varying from 10 to 80. The analysis result is delineated in Fig. 3, and it shows that the fuel's filtering efficiency is between 0.75 and 0.82. Since the p-value is

greater than 0.05, it can be concluded that there is no difference between them in the view of statistics.

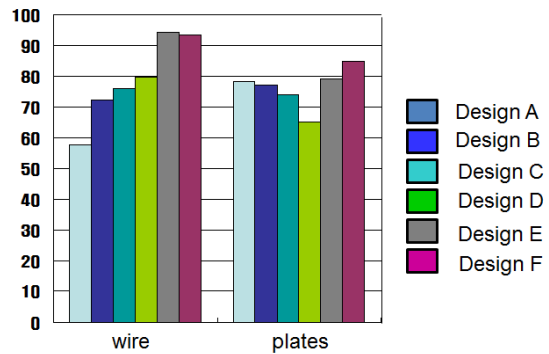

Fig. 2 Debris filtering performance depending on the type of debris

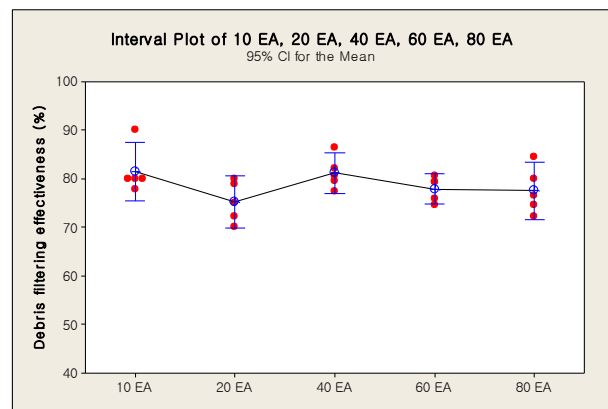

Fig. 3 Typical example of trapped debris

### 4. Conclusions

Debris induced fuel failure is one of major failure mechanism in the nuclear fuel. Therefore, the filtering capability should be implemented in the fuel. Debris filtering performance can be measured through a debris filtering test. In this paper, KEPKO NF developed test facility is introduced and a few test results are presented.

### REFERENCES

- [1] V. Inozemtsev, V. Onufriev, "Results of the IAEA Study of Fuel Failures in Water Cooled Reactors in 2006~2010", Top Fuel 2013, pp.238-244, 2013.