

## Open-Phase Condition Detecting System for Transformers in Nuclear Power Plant

Che-Wung Ha\*, Do-Hwan Lee

KHNP Central Research Institute, 1312-70 Yuseongdae-Ro, Yuseong-Gu, Daejeon 305-343, Korea

\*Corresponding author:hachewung@khnp.co.kr

### 1. Introduction

Recently, several events involving the loss of one of the three phases of the offsite power circuit occurred in the US nuclear power plants (NPPs). In some cases, the open-phase condition existed undetected for an extended period and in other case, was not properly responded to. Accordingly, the Nuclear Regulatory Commission (NRC) requested all license holders to take corrective actions to address the open-phase condition.

It was also requested that all holders or applicant for a standard design certification (DC) include a description of a protection system to detect and separate the open circuit into design control document (DCD). Currently, NPPs including Duke Energy, Exelon, and institutes including Electric Power Research Institute (EPRI) are working together to resolve issues associated with detecting an open-phase condition.

This paper, using Electromagnetic Transients Program (EMTP), presents a system to detect and address the loss of one of three phases of the offsite power circuit connected to main, auxiliary and standby transformers, which is hard to be detected in the current protection system.

### 2. Loss of Phase Events and Major Issues

#### 2.1 Overseas Events

NRC Information Notice 2012-03 introduces loss of phase events occurred in NPPs and the events are summarized as follows:

○ On January 30, 2012, Byron Station Unit 2 experienced a reactor trip from full power because of an under-voltage condition on the two 6.9kV buses that power reactor coolant pumps (RCPs) B and C. The cause of the event was the loss of phase C of offsite power as shown in Fig. 1. The unbalanced voltage caused RCP A and D to trip. Even though phase C was on an open circuit condition, power was provided to the engineered safety feature (ESF) buses A and B. Approximately 8 minutes after the reactor trip, the loss of phase C condition was identified and breakers were manually tripped to separate the unit busses from the offsite power source, the loss of ESF bus voltage was caused the emergency diesel generators (EDGs) to automatically start. Fig. 2 shows the single line power distribution of Byron Station.

○ On November 27, 2007, Beaver Valley Power Station Unit 1 discovered the broken phase A conductor of a 138kV offsite power circuit during a walk-down of the

offsite switchyard. The train A offsite power circuit was declared inoperable. Subsequently, it was revealed that the break on the 138 kV phase A had occurred 26 days earlier.

○ On December 5, 2005, at James A. FitzPatrick Nuclear Power and Nine Mile Point, Unit 1, an open circuit on phase A of the 115kV offsite power line was identified and it was found that the failure had existed, undetected for approximately 21 days.

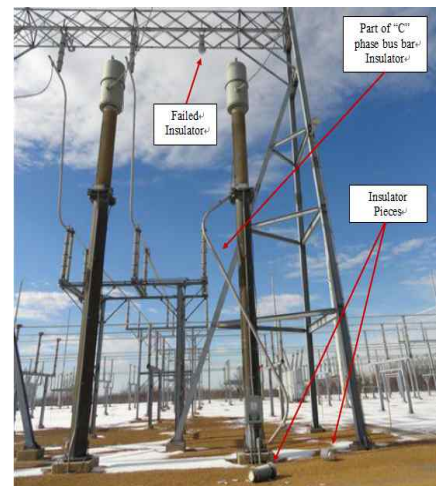

Fig. 1. Loss of Phase Event at Byron Station

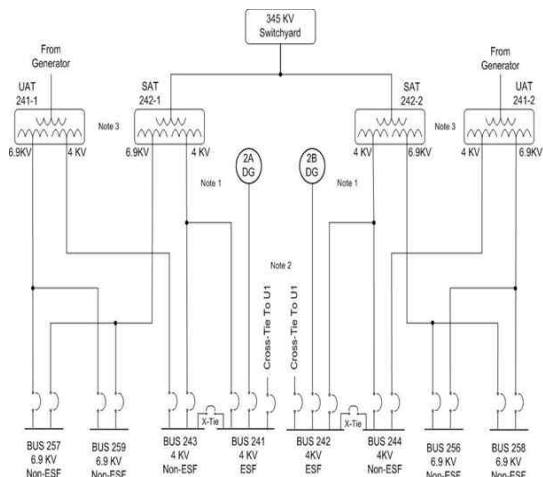

Fig. 2. Single Line Power Distribution Diagram

#### 2.2 Current Status of NRC Regulation

The NRC requested the license holders to provide information about their facilities' electric power system designs that describes how the protective system for ESF buses is designed to detect and automatically respond to a single phase open circuit condition (NRC Bulletin 2012-01). Most of the 104 US NPPs provided



information, explaining that the protective system was not designed to detect and automatically respond to single phase open circuit condition, but designed to isolate the ESF buses upon complete loss of offsite power, thereby satisfying the regulatory requirement. The NRC classified offsite power system designs of the US nuclear power plants into five groups and concluded that all of them needed improvement and made recommendations as follows[2] :

- Improve design to detect single phase open circuit condition.
- Prepare and execute a procedure to monitor the availability and operability of the three phases of offsite power source to the ESF buses during normal operation at least once per cycle.

### 2.3 WANO Recommendations

Based on lessons learned, WANO (World Association of Nuclear Operators) recommended that plant personnel should verify that the protection system has sufficient sensitivity to detect and automatically respond to single phase open circuit conditions on offsite power supplies to vital electrical busses[3].

- Determine the interim compensatory actions needed to detect degraded offsite power sources due to a single phase open circuit condition.
- Verify/provide operating procedures to help operators promptly diagnose and respond to single phase open circuit conditions on offsite power supplies to vital electrical buses.
- Verify guidance exists for manual configuration of electrical buses when automatic bus transfers fail to actuate or when manual alignment of emergency power is necessary.

It is also recommended that plant personnel should identify long term corrective actions to provide automatic protection from a single phase open circuit condition for offsite power sources supplying vital electrical buses.

## 3. Simulation Model and Results

### 3.1 EMTP Model

EMTP was used to conduct a simulation to identify and address issues associated with the loss of one of three phases of offsite power circuits running to a transformer in a NPP. It was modeled that main transformer (MT), unit auxiliary transformer (UAT) and stand-by auxiliary transformer (SAT) are connected to the power sources and three induction motors provide power to loads as shown in Fig. 3. Then, voltage and current were measured and compared when single phase open circuit condition occurred. The input data used in

the model was actual data on generator, transformers and motors in the operating NPPs in Korea.

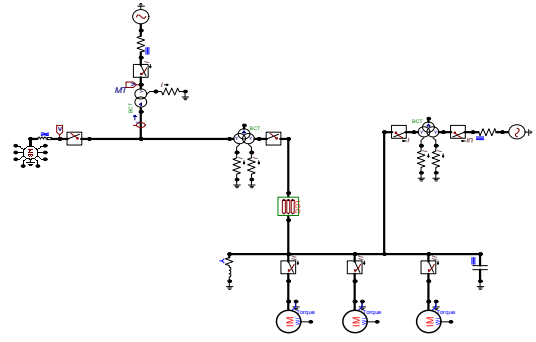

Fig. 3. Simulation of NPP using EMTP

### 3.2 Simulation Results

As shown in Fig. 4, a voltage drop in the secondary circuit of transformers did not occur significantly under single phase open circuit condition because of V-connection of transformers. Due to the constraint of paper length, in this paper, a SAT only is taken as an example to explain the simulation results. Fig. 4 shows the voltage drop in the secondary circuit of the SAT when the open-phase condition was occurred at the point of 0.5 second after the power provided to the loads. It was found that the peak value of phase C voltage was lowered from 11.267kV in normal condition to 10.973kV under single phase open circuit condition.

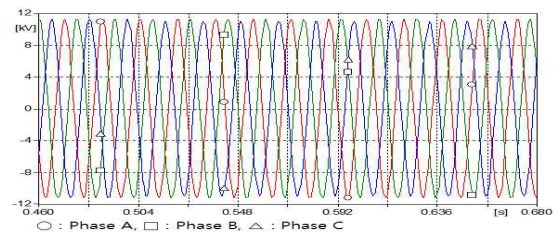

Fig. 4. Voltage Waveform of Standby Transformer upon Loss of Phase

In particular when the secondary circuit of the SAT is open-circuited in normal times, the voltage dropped from 11.267kV to 11.220kV, with no load connected. However, in both cases, a voltage drop was too minor for an under-voltage relay to detect. Therefore, consideration was given to the system protection method to detect current changes using a bushing type current transformer, rather than voltage changes.

The flow of current on one phase of the motor when the secondary circuit breaker of the SAT was decreased about 10% from 111.93 Amp to 101.13 Amp while the current on the other phases increased due to unbalanced current as shown in Fig. 5. If the unbalance condition continues for an extended period, it would lead to a motor failure and in worst case, a reactor trip. However, it is not possible to detect an open-phase condition in



the power line running to the primary side of the SAT while the secondary is open-circuited.

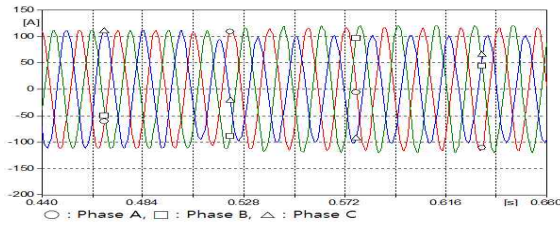
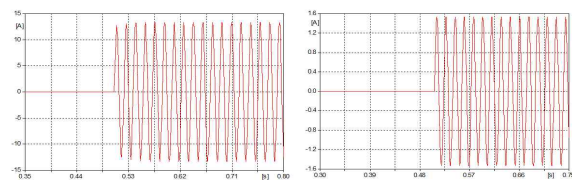

Fig. 5. Waveform of Unbalanced Current to Motor

#### 4. Open-Phase Detection System in Nuclear Power Plants

Currently many studies initiated by the license holders in the US are in progress to address issues associated with detecting an open-phase condition. This paper presents a system to detect an open-phase condition in the power line running to a transformer easily with no significant modification to the existing system. In particular when the secondary circuit of a transformer is open-circuited, as with the SAT, an open-phase condition on the power line to the transformer can be detected based on the flow of zero phase current measured in the neutral line of the transformer using a Rogowski coil current transformer, which makes it possible to send a signal to open the secondary circuit breaker of the transformer automatically or to send an alarm for a main control room (MCR) operator to take a proper action.



a) On-load Operation of SAT      b) No-load Operation of SAT

Fig. 6. Waveform of Current Flowing in the Neutral Line of SAT upon Loss of Phase

As shown in Fig. 6 a), when an open-phase condition of a SAT occurs with load connected, zero phase current flows ranging from several Amp to tens of Amp, and even with no load connected (Refer to Fig. 6 b)), the current ranges from tens of mili Amp to several Amp. It means that it is possible to measure zero phase current flowing through the neutral line of a SAT using a Rogowski coil current transformer installed, separately from a current transformer for ground overcurrent detection, and then use the value as an input signal for actuation of relay or alarm. In particular, a Rogowski coil raises no concern over thermal runaway due to overcurrent including a line to ground current because the coil is coreless type.

When the current flowing through the Rogowski coil is above a set point for a certain period of time while the

secondary circuit of SAT is open-circuited, it is possible to send an alarm for a MCR operator to take a proper action. When the secondary is closed-circuited, the Rogowski current measuring sensor can be disabled. (Refer to Fig. 7) Regardless of whether the secondary of a MT, UAT or SAT is open-circuited, it is not difficult to measure the flow of zero phase current, and when the value measured is above a set point for a certain period of time, to send a signal to operate a circuit breaker automatically or send an alarm for a MCR operator to take a proper action so as to detect an open-phase condition. However, no voltage change should be measured together to make it clear that overcurrent is not caused by a single line to ground fault etc.

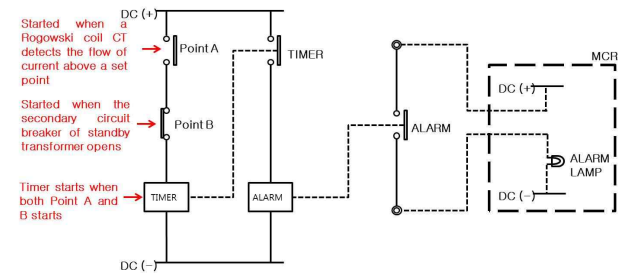

Fig. 7. Logic of Open-Phase Detection System for SAT

#### 5. Conclusion

This paper, using EMTP, presents a system to detect and address the loss of one of three phases of the offsite power circuit running to MT, UAT or SAT which is hard to be detected in the current protection system.

The system presented in this paper will be useful not only for the KHNP to meet the NRC requirement, but also for nuclear power plants at home and abroad to take corrective actions to provide protection from a single phase open circuit condition for offsite power sources.

#### REFERENCES

- [1] R. Arritt, et, Development and Analysis for an Open-Phase Detection System, EPRI, September 2012.
- [2] Bulletin 2012-01, Design Vulnerability in Electric Power System, NRC, July 2012.
- [3] Significant Event Report 2012-2, Delayed Automatic Actuation of Safety Equipment on Loss of Offsite Power Due to Design Vulnerability, WANO, June 2012.

