

GAMMA-FR and MELCOR Validation using HCS Heat Exchanger Break Accident

Hyung Gon Jin^{a*}, Yunjeong Hong^a, Seungyon Cho^b
^aKorea Atomic Energy Research Institute, Republic of Korea
^bNational Fusion Research Institute, Republic of Korea
^{*}Corresponding author: jhg@kaeri.re.kr

1. Introduction

This paper presents the accident analyses results of helium pipe rupture in main HX to CCWS-1, which is category I chit for the conceptual design of HCCR-TBS. To confirm the HCCR-TBS integrity, enveloped cases from the conceivable events were evaluated and demonstrated compliance with the General Safety Objectives of ITER..

2. Related System Description

The Helium Cooling System (HCS) shall provide the primary coolant, i.e. helium, at the characteristic pressure, temperature and mass flow rate required by the HCCR TBM for testing and extraction of the heat produced. [1].

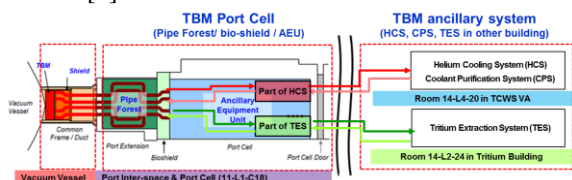

Figure. 1 Schematics of HCCR-TBS

CCWS-1 is a closed loop system [Fig 2]. The main source of contamination is identified in CCWS-1 water is tritium and activated corrosion product. The only source of contamination to CCWS-1 may occur through CCWS-1 clients. Pressure on the HCCR-TBS side of heat exchanger is higher than that of CCWS-1 side. Hence, CCWS-1 system may get contaminated. Double isolation valves will be provided for HCCR-TBS to isolate the leakage to CCWS-1 system

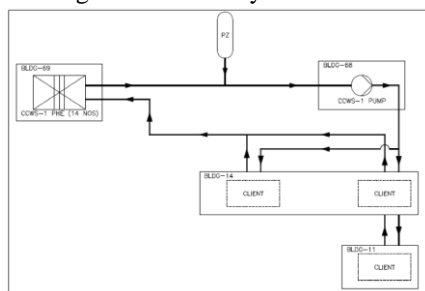

Figure. 2 Schematics of CCWS-1

3. Description of the accident

This accident is initiated by failure of cooling channel(s) of the heat exchanger in the cooling circuit. Table 1 describes specification for the analysis. In table 2, main parameters for the accident are shown.

Parameter	Specification
Name of event	- Helium pipe rupture in main HX to CCWS-1
Category	- Accident
Objectives	- Check that the accidental over-pressure in CCWS-1 - Check that radioactive release
Scope of analysis	- Coolant temperature/pressure transient at CCWS-1 - Radioactive release to CCWS-1 and environment via CCWS-1 pressurizer for chronic & accidental cases
Acceptance criteria	- Max pressure < the design pressure 1MPa in the CCWS-1 - Radioactive release (tritium) to CCWS-1 < 370 GBq & 10 MBq/m ³ - Accident doses << General Safety Objectives for accidents

Table. 1 Specification of Helium pipe rupture in main HX to CCWS-1

Parameter	Value
CCWS-1 total loop volume	3100 m ³ [4.1]
CCWS-1 pressurizer volume	40 m ³ (nitrogen: 88%) [4.2]
Inlet Temperature to the primary side of PHE	72 °C [4.2]
Pressure at inlet of the primary side of PHE	0.4 MPa [4.2]
CCWS-1 total mass flow rate	6230 kg/sec [4.2]
Relief Valve Opening Pressure	0.41 MPa [4.2]
Relief Valve Closing Pressure	0.39 MPa [4.2]

Table. 2 Parameters for Helium pipe rupture in main HX to CCWS-1

4. Modeling

In this analysis, amount of discharged helium is the key parameter to examine total tritium ingress to CCWS-1. In this regard, radiation heat transfer and temperature distribution along the pipes did not take account. Due to the same reason, flow network inside of TBM is simplified as one fluid volume (FB1300). PCHE, which is inside of the red color rectangle has many narrow channels. In this nodalization, FB1500 and 1510 are HCS side, and FB401 and 402 are designated for CCWS-1 side. FB1510 and 401 represent ruptured channels, which are connected when accident happens. And FB1500 and 402 volumes are unbroken channels.

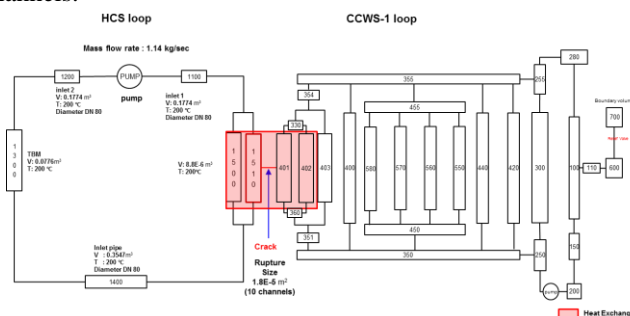

Figure. 3 HCS + CCWS-1 nodalization

CCWS-1 consists of four major components such as pressurizer, pumps, primary heat exchanger and clients. Based on the hydraulic analysis report for CCWS-1. 6 TBSs are allocated in parallel and HCCR TBS is one of them. Total mass flow rate for all TBSs is 96 kg/sec,

therefore, HCCR-TBS mass flow rate at CCWS-1 is assumed 1/6 of 96 kg/sec, which is 16 kg/sec.

Total mass flow rate of CCWS-1 is 6230 kg/sec but mass flow rate at each junction depends on its location. In the GAMMA-FR nodalization, neighboring volumes in CCWS-1 nodalization are combined and simplified. Relief valve opens when the pressure (FB600) exceeds 0.41 MPa and it takes one second to be fully opened. And it is closed when the pressure decreases below 0.39 MPa. As an initial condition, 88% of the pressurizer volume is filled with nitrogen. Those two parameters should be considered because relief valve cuts overpressure in the CCWS-1 and nitrogen volume mitigates instant pressure build-up in the pressurizer

5. Results

Key parameters, which govern this transient, are relief valve operation, nitrogen in the pressurizer and flow area of the ruptured channels. Relief valve in CCWS-1 pressurizer opens at 0.41 MPa and closes 0.39 MPa, therefore, CCWS-1 pressure is impossible to exceed 0.41 MPa globally. As a comparison, calculation was conducted against CCWS-1 with relief valve (with RV) and without relief valve (without RV).

Fig. 4 shows pressure build-up transient in the ruptured channels. 8 MPa helium ingresses through the leak path and channel pressure rapidly reaches maximum pressure and then drops with time. PCHE flow channel is so narrow that it is easy to pressurized, in the same manner flow area of each channel is small as well. This means that choked flow happens at the end of CCWS-1 side PCHE ruptured channels and it makes hard to build pressure at the volumes nearby which are comparatively much bigger than channel volume.

Fig 4 shows general pressure trends of this accident. Most of all fluid volumes have the same pattern. As a representative one, red line indicates pressure curve at FB350 without relief valve operation. After the accident starts, it oscillates a lot by the effect of discharging high pressure helium to CCWS-1. It is much severe in a small volume. For example, FB355, which is small volume, shows similar oscillation at the beginning, however, pressurizer volume FB600 (40m³) does not have pressure oscillation. Another small oscillation appears at 500 seconds, which can be observed when divided helium flows at ruptured channel meet at the other side of the CCWS-1 loop. Without relief valve operation, pressure continuously increases over time.

For the more realistic approach, relief valve operation and nitrogen in pressurizer (88% of pressurizer volume) are taken into account (Black line). Pressure trend is the same as 'without relief valve' case until valve opens. If a fluid volume is away from the relief valve, maximum pressure temporally exceeds 0.41 MPa but there is no such a volume, which is over the safety limit (1 MPa)

except ruptured channels themselves. While valve opens, pressure drops and rebounds near 0.39 MPa after valve closes. This type of wavy trends can be found in all CCWS-1 components

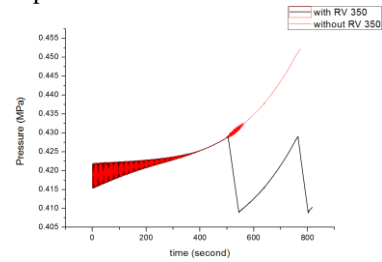

Figure. 4 HCS + CCWS-1 nodalization

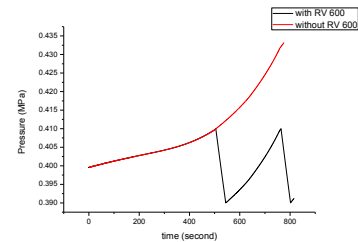

Figure. 5 HCS + CCWS-1 nodalization

6. Conclusion

In principle, transient of this accident is similar to LOHSA, therefore, TBM temperature is expected to be cool down by passive cooling and isolation valves avoid CCWS-1 pressure build-up during the accident. With relief valve, pressure of CCWS-1 is under 0.43 MPa during LOCA happens. (CCWS-1 max. design pressure: 1MPa). On the other hand, primary concern is tritium concentration increase in CCWS-1 because of tritium contents in HCS coolant. The important point is that CCWS-1 is an ESP device and its ESP level should be confirmed when operating with HCCR-TBS as well. ESP/ESPN classification check is valid in an incident, however, conservatively tritium concentration of whole system including CCWS-1 was examined during this accident. In total,

$$20 \text{ years operation} + \text{accident case} \\ = 0.21 \text{ MBq/m}^3 + 0.35 \text{ MBq/m}^3 < 10 \text{ MBq/m}^3$$

This means HCCR TBS operation does not affect ESP/ESPN classification of CCWS-1.

7. Acknowledgement

This work was supported by the R&D Program through the National Fusion Research Institute (NFRI) funded by the Ministry of Science, ICT and Future Planning of the Republic of Korea (NFRI-IN-1503).

8. References

- [1] Hyung Gon Jin, "HCCR-TBS Accident Analysis Report", QQL5TP V1.0 (2015)
- [2] Design calculations and analysis report of CCWS (9K77X9)
- [3] Hydraulic Analysis Report for CCWS (PF7BXH)