

Development of Commercial-scale Fission Mo-99 Production System

Seung-Kon Lee*, Won Je Cho, Suseung Lee, Soon-Bog Hong, Kyung-Duk Jang, Ul Jae Park, Jun Sig Lee
Division of Radioisotope Research, Korea Atomic Energy Research Institute, 989-111 Daedok-daero, Yuseong-gu,
Daejeon, 305-353 Republic of Korea

*Corresponding author: seungkonlee@kaeri.re.kr

1. Introduction

Molybdenum-99 (^{99}Mo) has been one of the most important isotopes for more than 50 years. Since its daughter isotope $^{99\text{m}}\text{Tc}$ is the most commonly used medical radioisotope which covers 85% of overall nuclear diagnostics. [1-2] More than 95% of ^{99}Mo is produced through fission of ^{235}U because, ^{99}Mo generated from the fission (fission ^{99}Mo) exhibits very high specific activity ($\sim 10^4\text{Ci/g}$). These days, worldwide ^{99}Mo supply is not only insufficient but also unstable. Because, most of the main ^{99}Mo production reactors are more than years old and suffered from frequent and unscheduled shutdown. Therefore, movement to replace old reactors to keep stable supply is now active. Under these conditions, KAERI (Korea Atomic Energy Research Institute) is developing LEU-based fission ^{99}Mo production process which is connected to the new research reactor (Kijang New Research Reactor, KJRR), which is being constructed in Gijang, Busan, Korea.

Historically, the most fission ^{99}Mo producers have been used highly enriched uranium (HEU) targets so far. However, to reduce the use of HEU in private sector for non-proliferation, ^{99}Mo producers are forced to convert their HEU-based process to use low enriched uranium (LEU) targets. Economic impact of a target conversion from HEU to LEU is significant. Overall cost for the production of the fission ^{99}Mo increases significantly with the conversion of fission ^{99}Mo targets from HEU to LEU. It is not only because the yield of LEU is only 50% of HEU, but also because radioactive waste production increases 200%. [3] On the basis, worldwide efforts on the development of ^{99}Mo production process that is optimized for the LEU target become an important issue. [4-6] KAERI is developing LEU-based ^{99}Mo production process to be implemented for the KJRR.

2. Methods and Results

Target: In KAERI's fission ^{99}Mo process, plate-type LEU target with UAlx meat and Al-6061 cladding is used. Compared with general pulverized UAlx powders, KAERI's powders prepared by the unique centrifugal atomization technology have spherical shape with small surface area (Fig. 1a and 1b). And, those differences may lead to different dissolution behavior during the chemical process.

Process: Targets with atomized UAlx powders are dissolved in sodium hydroxide solution to extract ^{99}Mo

into the solution. Other fission products including unreacted uranium and actinides are removed from the solution. Medical-grade ^{99}Mo can be extracted after proper chemical treatments and multi-step separation and purification process. KAERI's research team developed new technology to facilitate waste treatment by converting sludge-type waste, which is difficult to handle, into independent solid and liquid wastes. The overall scheme of the KAERI's fission ^{99}Mo process is presented in Figure 1c. Full-scale production system is presented in Figure 1d.

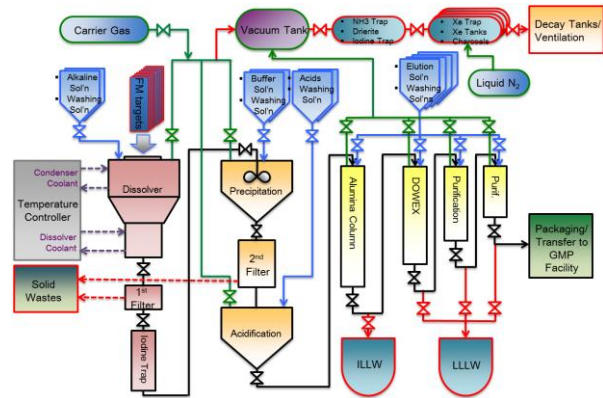

Fig. 1. (a), (b) Scanning micrograph of the meat surface from a KAERI's plate-type LEU target. (c) Scheme for the KAERI's fission Mo-99 process. (d) Full-scale production system.

Analysis: To find optimized dissolving condition for the KAERI's fission ^{99}Mo with atomized UAlx powders, we designed systematic experiments with a matrix of temperature, solution concentration, additives and mechanical mixing. Figure 2a-2d shows precipitates of the KAERI's fission ^{99}Mo target under different concentration of solution and additives, those are collected after dissolution process. Figure 2e shows scanning electron micrographs from the uranium precipitates dissolved in the optimized condition. Energy dispersive X-ray spectroscopy result is also presented in Figure 2e. The component ratio presents that the precipitates are uranium oxide and/or sodium diuranates.

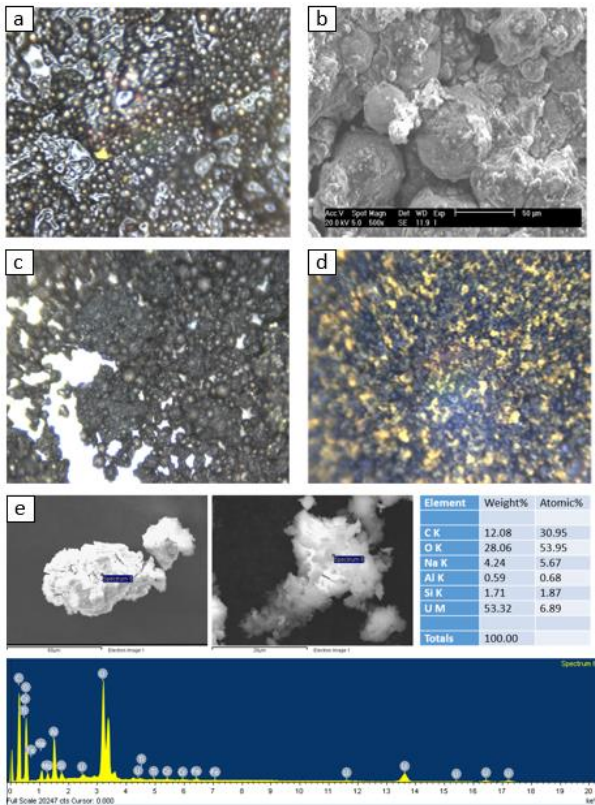

Fig. 2. Analysis of uranium precipitates after dissolution. (a), (b) Optical and Scanning electron micrograph of the uranium powder with deficient sodium hydroxide concentration. (c) Optical micrograph of the uranium powder created at optimal sodium hydroxide concentration without oxidant. (d) Optical micrograph of the uranium powder created with optimal sodium hydroxide and concentration. (e) Scanning electron micrographs and energy dispersive X-ray spectroscopy result of the uranium powder created with optimal sodium hydroxide and concentration.

3. Conclusions

In this study, fission ^{99}Mo process with non-irradiated LEU targets was presented except separation and purification steps. Pre- and post-irradiation tests of the fission ^{99}Mo target will be done in 4th quarter of 2016. For the fission Mo production process development, hot experiments with irradiated LEU targets will be done in 4th quarter of 2016. Then, verification of the production process with quality control will be followed until the commercial production of fission ^{99}Mo scheduled in 2019. In the future, weekly productivity of 2000 Ci fission ^{99}Mo from the KJRR will cover 100% domestic demand (~150 Ci/wk) of Korea as well as about 18% of international market (International market: 10,000-12,000 Ci/wk).

REFERENCES

- [1] International Atomic Energy Agency, "Non-HEU Production Technologies for Molybdenum-99 and Technetium-99m", IAEA Nuclear Energy Series No. NF-T-5.4, 2013.
- [2] International Atomic Energy Agency "Fission Molybdenum for Medical Use", IAEA-TECDOC-515, 1989.
- [3] International Atomic Energy Agency, "Management of Radioactive Waste from ^{99}Mo Production", IAEA-TECDOC-1051, 1998.
- [4] M. V. Wilkinson, A. V. Mondino, A. C. Manzini, J. Radionucl. Nucl. Chem., Vol. 256, p. 413, 2003.
- [5] R. Muenze, G. J. Beyer, R. Ross, G. Wagner, D. Novotny, E. Franke, M. Jehangir, S. Pervez, A. Mushtaq, Sci. and Tech. of Nuclear Installations, 932546, p. 9, 2013.
- [6] S. Ditttrich, Sci. and Tech. of Nuclear Installations, 514894, p. 9, 2013.