

Transient Model of a 10 MW Supercritical CO₂ Brayton Cycle for Light Water Reactors by using MARS Code

Joo-Hyun Park^a, Sung Won Bae^b, Hyun Sun Park^{a*}, Moo Hwan Kim^a, Jae-Eun Cha^b

^aTwo-Phase Flow Laboratory, Division of Advanced Nuclear Engineering, POSTECH, 77 Cheongam-ro, Nam-gu, Pohang, Gyeongbuk, 37673, Republic of Korea

^bKorea Atomic Energy Research Institute, 111, Daedeok-daero 989beon-gil, Yuseong-gu, Daejeon, 34039, Republic of Korea

*Corresponding author: hejsunny@postech.ac.kr

1. Introduction

The supercritical CO₂ Brayton cycle (SCO₂BC) is considered as a power conversion system for next generation power plant. The SCO₂BC has advantages of high thermal efficiency, system compactness and wide operation range [1]. The high thermal efficiency comes from lower the compression work with the operation of compressor near the critical point. Due to the high density and thermal capacity of CO₂ near the critical point. However, the properties of SCO₂ drastically change near the critical point. Therefore smooth operation of the cycle near the critical point is important. However, it is one of the key technical challenges. Therefore understand of the cycle behavior is important. Therefore SCO₂BC was modeled in the MARS code for the analysis of the transient behavior of cycle operation near the critical point.

In this study, recuperation cycle was chosen as a reference loop design and the MARS code [2-3] was chosen as the transient cycle analysis code. Cycle design condition is focus on operation point of the light-water reactor. Development of a transient model was performed for 10MW-electron SCO₂ coupled with light water reactors. In order to perform transient analysis, cycle transient model was developed and steady-state run was performed and presented in the paper.

2. Transient model of SCO₂ recuperation Brayton cycle

In this section cycle layout and component design are described. The conventional reactors like a PWRs and SMRs was chosen as a target heat source of SCO₂ recuperation Brayton cycle power conversion system.

The SCO₂ recuperation Brayton cycle layout is shown in fig. 1. System 1 corresponds to the SCO₂ recuperation cycle as a main loop. System 2 and 3 are respectively represents the cooling water loop and the heating water loop.

Main loop system is consist of compressor, turbine, precooler, primary (intermediate) heat exchanger, recuperator. In order to save rejected heat and increase the total thermal efficiency of the cycle using recuperator. The models of the compressor use homologous curve [4]. The compressor and turbine are coupled to a motor generator through shaft. The shaft

imposes a rotational speed about 1190 (rad/s) when cycle operate with design condition. For the cycle control system, cycle transient model include six valve and inventory tank system. Control of pressure at the compressor inlet achieved using valve 889, valve 881 and inventory tank (time dependent volume 880 and 890). In order to control of power, bypass valve 873 is used.

System 2 and 3 has independent water loop respectively. Two loop connect to main loop by using heat structure respectively.

The target power generation system, reactor outlet temperature of PWRs and SMRs is criterion of turbine inlet temperature. Turbine inlet temperature is chosen about 583.15 K, from the operating range of SMART [5]. The most of previous conventional safety systems of PWRs and SMRs are based on the primary side coolant insurgent to the secondary side when is a steam generator tube rupture. In order to maintain similar safety systems design and operation philosophy, the cycle maximum temperature set the 15 MPa [6]. Therefore in this cycle, maximum temperature is 583.15 K, maximum pressure is 15 MPa.

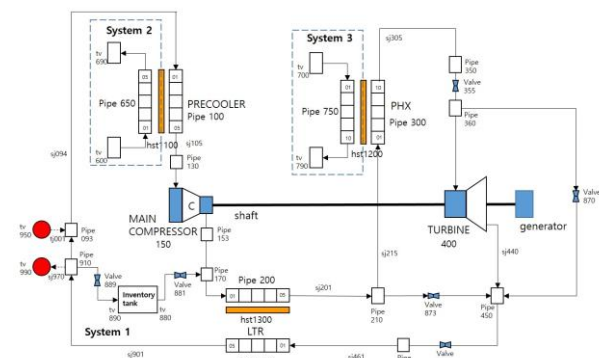

Fig. 1. Schematic diagram of SCO₂ recuperation cycle.

3. Steady-state results

In this section results of closed loop steady-state run are described. Closed loop model run after open loop reach steady-state and reach same condition at two point (pipe 910 and pipe 093).

Steady-state calculations have been run to test the performance of the cycle transient model. Table 1 show

the main parameters of the model. Main cycle system mass flow rate is 254.32 kg/s.

Table I: steady-state results

Cycle power output	9.87 (MW)
Compressor power	2.85 (MW)
Heat input to cycle	47.33 (MW)
Compressor inlet pressure	7.67 (MPa)
Compressor inlet temperature	305.65 (K)
Turbine inlet pressure	14.85 (MPa)
Cycle thermal efficiency	20.84 (%)
Shaft speed	1190 (rad/s)

The compressor inlet condition fixed at 7.67 MPa 305.65 K in order to decrease compressor work and test the cycle thermos-physical condition during transient analysis. SCO_2 cycle should work at near the critical point for cycle efficiency.

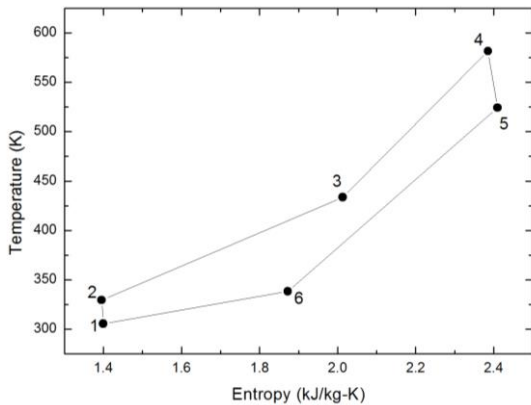

Fig. 2. Temperature-entropy diagram of SCO_2 recuperation cycle steady-state results.

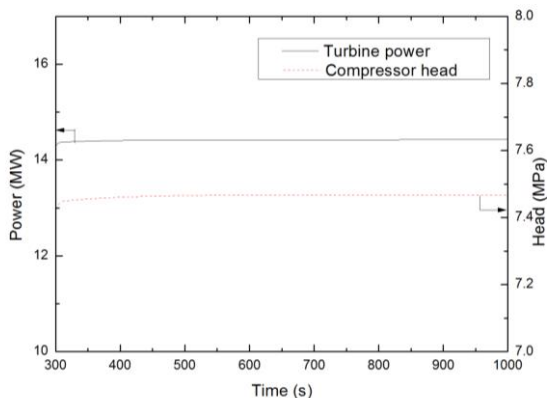

Fig. 3. Steady-state results of transient model.

Fig. 2 Shows temperature-entropy diagram after steady-state run. 1-2 line means compressor working region. 2-3 line means high pressure recuperator region. 3-4 line means heater region. 4-5 line means turbine

working region. 5-6 line means low pressure recuperator region. 6-1 line means precooler region.

Fig. 3 shows turbine power output and compressor head during steady-state run. Closed loop run start at 300s. The simulation results become steady-state after 500s. Turbine power and compressor head become stable after 500s.

4. Conclusions

In this study, the transient model of SCO_2 recuperation Brayton cycle was developed and implemented in MARS to study the steady-state simulation. We performed nodalization of the transient model using MARS code and obtained steady-state results. This study is shown that the supercritical CO_2 Brayton cycle can be used as a power conversion system for light water reactors.

Future work will include transient analysis such as partial road operation, power swing, start-up, and shutdown. Cycle control strategy will be considered for various control method.

REFERENCES

- [1] V. Dostal, M. J. Driscoll, and P. Hejzlar, "A Supercritical Carbon Dioxide Cycle for Next Generation Nuclear Reactor", *MIT-ANP-TR-100*, 2004
- [2] S. Y. Lee, J. J. Jeong, S. H. Kim, and S. H. Chang, "COBRA/RELAP5; A Merged version of the COBRA-TF and RELAP5/MOD3 codes", *Nuclear Technology*, Vol. 99, pp. 177-187, 1992
- [3] J. J. Jeong, S. K. Sim, and S. Y. Lee, "Development and Assessment of the COBRA/RELAP5 Code", *Journal of Nuclear Science and Technology*, Vol. 34, No. 11, pp.1087-1098, 1997
- [4] J. H. Park, H. S. Park, T. Kim, J. G. Kwon, S. W. Bae, and J. E. Cha, "Compressor Modeling for Transient Analysis of Supercritical CO_2 Brayton Cycle by using MARS code", *transactions of the Korean Nuclear Society Spring Meeting* Jeju, Korea, May 12-13, 2016
- [5] M. Chang, "Basis Design Report of SMART", Technical Report-2142, KAERI, Korea, 2002
- [6] H. J. Yoon, Y. Ahn, J. I. Lee, and Y. Addad, Potential advantages of coupling supercritical CO_2 Brayton cycle to water cooled small and medium size reactor", *Nuclear Engineering and Design*, 245, pp. 223-232, 2012