

Power Controller Design and Application to Research Reactor

Dane Baang*, Yongsuk Suh, and Seong Hoon Kim
Research Reactor System Design Div., Korea Atomic Energy Research Institute,
Deadukdae-ro 989-111, Youseong Gu, Daejeon City, Korea
*Corresponding author: dibang@kaeri.re.kr

1. Introduction

The design, simulation, and actual application result of a power control law is presented for a research reactor. We developed a simple and easy-to-implement controller with a limiting function of power-change-rate. This controller has been developed based on [1] and other works performed by KAERI during several decades of research reactor development experience. Various design features for reactor safety has been also considered in the controller design. It has been shown that the proposed controller has been successfully applied to actual reactor power control.

2. Controller Design, Simulation, and Application to Reactor

2.1 Plant Modeling

Regarding the input and output of the controller, the RRS receives field signals including neutron detector signal, which is the measured reactor power value to control. Using the designed feedback power control law the RRS generates control command as a form of the angular velocity for the step motor, installed in a CAR (Control Absorber Rod). The target reactor has four(4) CARs and the movement of each CAR results in reactivity insertion or removal to/from the reactor. If the control command is positive, for example, due to the step motor's clockwise rotation, the CAR is pulled up to insert the corresponding reactivity to the reactor, and vice versa.

The feedback power controller, which is a part of RRS (Reactor Regulating System) software logic, has been designed in a simulation environment with reactor model based on neutron point kinetics [2]. The model in the simulation includes the dynamics of the neutron and precursors, iodine and xenon, decay heat by fission products, and fuel, coolant, and reflector temperatures by means of the well-known point kinetics and dynamics model [6], which is omitted in this paper.

The simulation tool used to implement the control loop is *SIMULINK* that is an *MATLAB*-based GUI environment for multi-domain simulation and model-based design for dynamics. Fig. 1 shows the neutron point kinetic equation in vector form, a part of plant model implemented by Matlab /Simulink [2, 5].

2.2 Simulation and Power Controller Design

The reactor power control logic is demonstrated in Fig.2. The main idea of power control algorithm is to track the power demand, as long as limiting the change rate of power(i.e., log-rate) to a pre-defined value(5%PP/s in this paper). The control logic operates as in Fig 1.

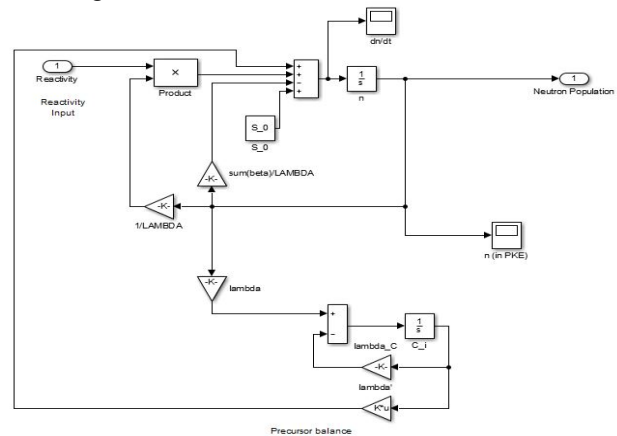

Fig. 1. Neutron Point Kinetic Equation in Vector form-modeling by MATLAB/SIMULINK

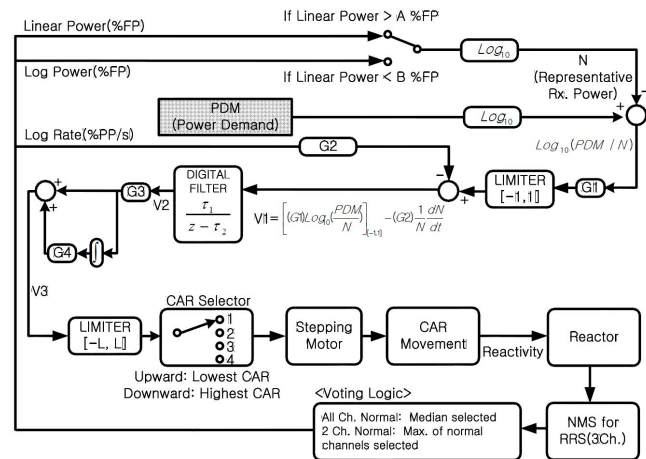

Fig. 2. Proposed Power Control Algorithm.

The logarithm of the ratio of the demand power to the current power $\text{Log}(PDM / N)$ should be equal to zero at a steady state and, therefore, this value is used to make the error signal for the controller. The maximum reactivity change per unit time should be limited for the safety purpose and, for this purpose, the controller is designed in such a way that the log-rate $((1/N)(dN/dt))$ will not exceed 5% PP/s (Percent of

the Present Power per Second) during the whole control process. So the log rate signal should be also chosen to be included in the error signal. Thus we define the error signal for P-control as

$$V1 = [(G1) \text{Log}(\frac{PDM}{N})]_{|_{\pm 1}} - (G2) \frac{1}{N} \frac{dN}{dt}$$

If this $V1$ is positive, the selected CAR will be withdrawn and if it is negative, the CAR will be inserted. Only one CAR is selected at a time in this method.

When the reactor output N is small, the term $(G1) \text{Log}(\frac{PDM}{N})_{|_{\pm 1}}$ is big, but due to the $[-1,1]$ limiter, it remains 1. The log rate term $(G2) \frac{1}{N} \frac{dN}{dt}$ is very small at this stage. So $V1$ is almost 1 and P-control with the gain $G3$ generates the maximum control action, which leads to upward movement of the selected CAR with maximum speed. In result the reactor power increases, and the log rate $(1/N)(dN/dt)$ also grows up. So $V1$ decreases gradually until $(G2/N)(dN/dt)$ becomes 1 (i.e., $V1=0$), which consequently makes the CAR stop.

Since $G2=0.2$, the CAR's upward movement stops and resumes with the log rate of 5%PP/s as a set-point. The integral control action was also adopted to reduce steady-state error. The up/down limiter finally limits the CAR speed to the permitted range by safety analysis.

2.3 Application to Actual Reactor

The designed controller has been simulated (omitted in this paper), and applied to an actual research reactor during its commissioning tests. The control performance in Fig.3 shows that the proposed controller regulates the reactor power to each target power varying from 1e-3%FP(Full Power) to 100%FP accurately without large overshoot. In this test the power up to 1e-3%FP has been reached manually. The figure also shows that the CAR critical positions increase to compensate the negative reactivity feedback.

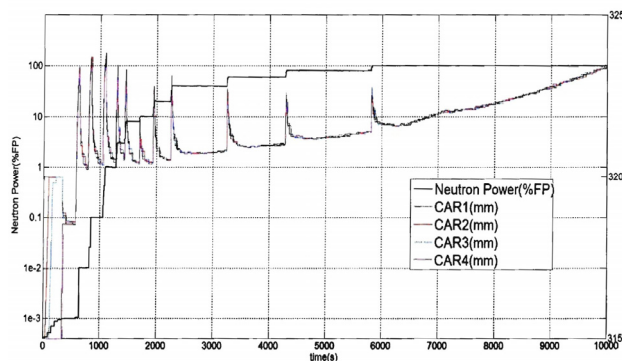

Fig. 3. Power control performance in commissioning test(during 10,000s) with the PDM changes in sequence from 1e-3%FP to 100%FP

The overshoot around the full power(100%FP) is important in order to avoid unwanted reactor trip, since the reactor trip setpoint is about 110%FP. Fig. 4 shows that the maximum overshoot around the full power is lower than 1%FP, which is quite smaller than the setpoint. The noisy measures after overshoot may be more reduced by proper filtering of power signals.

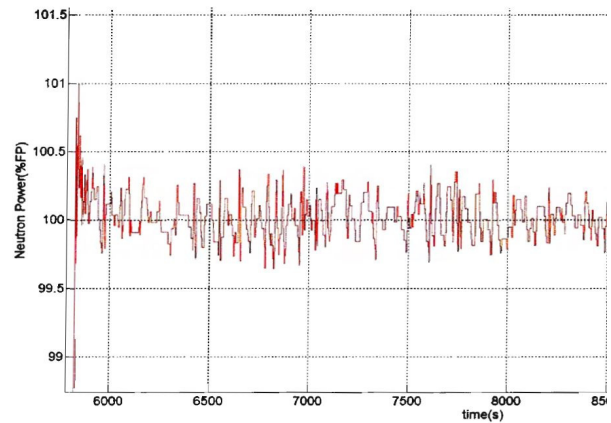

Fig. 4. Power overshoot at around full power

3. Conclusion

A simple power controller a research reactor has been designed, simulated, and applied to a research reactor. The commissioning test (power ascension test) results show that the proposed controller provides accurate and fine control performance for various constant target power values. Further research may include model-based approach to obtain proper robustness to disturbances.

REFERENCES

- [1] Dane Baang, Youngsuk Suh, and Cheol Park, Feedback Power Control for TRIGA-II Research Reactor, KNS spring meeting, May 18-19, Jeju, 2017.
- [2] Sungjin Kim and Dane Baang, Program Description and Functional Test of RRSSIM, JR-TR-SA-013, KAERI, 2011.
- [3] Taewan Noh, B.S. Sim, B.W. Rhee, S.K. Oh, Program Description of KMRRSIM, KAERI Technical Report, KM-031-400-01, 1989.
- [4] Taewan Noh, B.S. Sim, S.K. Oh, Functional Test Program for KMRR Programmable Controller, KAERI Technical Report, KM-031-400-02, 1989.
- [5] MATLAB/SIMULINK User's Guide, Mathworks, 2001
- [6] M.A. Schultz, Control of Nuclear Reactors and Power Plants, McGRAW-HILL, 1955
- [7] G.H. Hostetter, Digital Control System Design, Holt, Rinehart, and Winston, New York, 1988
- [8] Chi-Tsong Chen, Linear system theory and design, Oxford university press.,1999.
- [8] KAERI Inter-Office Correspondence: IOC-SA-11-008, 2011