

## Investigation of Polyethylene Terephthalate in Different Thickness with Coincidence Doppler Broadening Spectroscopy

Junyoung Lee <sup>a,b</sup>, Jaegi Lee <sup>a\*</sup>, Gwang-Min Sun <sup>a</sup>, Young Rang Uhm <sup>a</sup>, Sung-Joon Ye <sup>b</sup>

<sup>a</sup>Neutron and Radioisotope Application Research Division, KAERI, 111 Daedeok-daero 989beon-gil, Daejeon, 34057

<sup>b</sup>Program in Biomedical Radiation Sciences, Department of Transdisciplinary Studies, Graduate School of Convergence Science and Technology, Seoul National University, Seoul, 08826

\*Corresponding author: jgl@kaeri.re.kr

### 1. Introduction

Positron annihilation spectroscopy is mainly divided into two methodologies: positron annihilation lifetime and the Doppler broadening of the annihilation gamma-rays. Positrons injected into a dense matter are almost instantly thermalized by the repulsive force from the nucleus. The energies of the positron annihilation photons are shifted by the Doppler effect, where the quantity of the gamma-ray energy shift is correlated to the momentum distribution of electrons. The core electrons which have high momentum compared to the valence electrons provide distinctive information of the carbon covalent bond like the C=O group[1]. Nevertheless, the detection of annihilation gamma-rays from the core electrons is a challenging task, due to both the rarity of core electron annihilation events and the comparatively dominant Compton background signal acting as a noise. To enhance the signal-to-noise ratio of the energy spectrum of the annihilation gamma-rays, the coincidence Doppler broadening spectroscopy (CDBS) with two germanium detectors was introduced[2]. In this setup, the peak to the background ratio is dramatically improved in the tail region and the contribution of the core electrons can be easily extracted.

Polyethylene terephthalate (PET) is one of the promising candidate materials for coating film to block the low atomic number materials. During the PET fabrication, a few hundred micro-meter thick PET sheets may be expanded by going through certain types of processes. The purpose of this study was to observe molecular level structural difference, if any, between products of different manufacturing procedure by Doppler broadening spectroscopy.

### 2. Methods and Results

#### 2.1 System Setup

The KAERI coincidence Doppler broadening spectroscopy system consists of two HPGe detectors (Ortec GMX40P4-76), a dual 5-kV detector bias supply (Ortec 660), two amplifiers (Ortec 570), and a coincidence module (Labo NT24-DUAL). The coincidence module contains two analog-to-digital converters (ADC) with a maximum of 4096 channels available and a coincidence timing module. The coincidence timing window was set to 1  $\mu$ s. The distance between two HPGe detectors was set to 30 cm with

source in the middle, as the detectors were diametrically opposed. The ADC channels of two detectors were calibrated by <sup>22</sup>Na and <sup>226</sup>Ra sources. The four typical prompt gamma-rays from the <sup>226</sup>Ra source with energies of 186.1, 242.0, 295.2, and 351.9 keV as well as the 511 keV annihilation gamma-ray from <sup>22</sup>Na were counted to determine the channel-energy calibration curve. Each measurement lasted for about 20 hours, for annihilation peaks count data to accumulate at least  $8 \times 10^4$  counts. The shaping time of the amplifiers was 2  $\mu$ s. A 30  $\mu$ Ci <sup>22</sup>NaCl source was placed between 2.5- $\mu$ m nickel foils. The samples sandwiched the <sup>22</sup>NaCl source. The direction angle of the samples to the HPGe detectors was 45° for simultaneous measurements of positron annihilation lifetime spectroscopy.

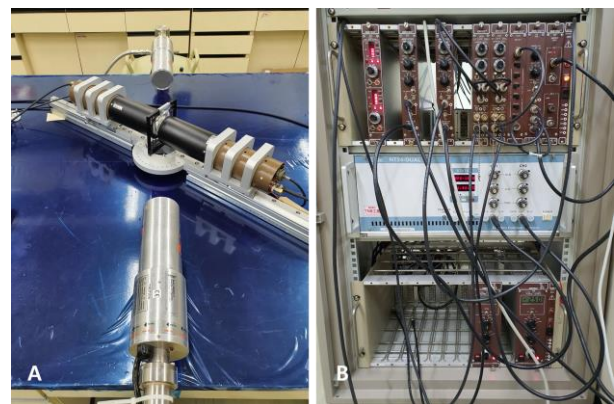
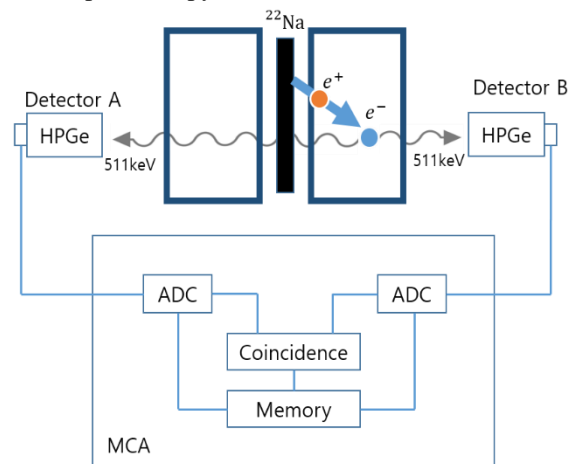

Fig. 1. Typical schematic diagram of coincidence Doppler broadening spectroscopy (CDBS) system. B) Radioisotope source and HPGe detector. C) Detector bias supply, amplifiers and a coincidence module.

## 2.2 Experimental Result

The contour plot of the coincidence spectrum is shown in Fig. 2. The horizontal and the vertical bands correspond to the intensities of the annihilation gamma rays of the individual detector. The intense peak at the center matches with the counts for annihilation photons with an energy of 511 keV. The elliptical region extending diagonally, where the sum of two photons is equal to 1,022 keV, illustrates the pure Doppler shift.

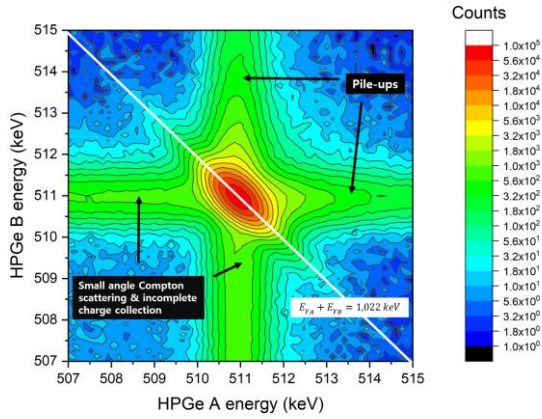

Fig. 2. Two-dimensional contour plot of the coincidence energy spectrum of the observed gamma-rays.

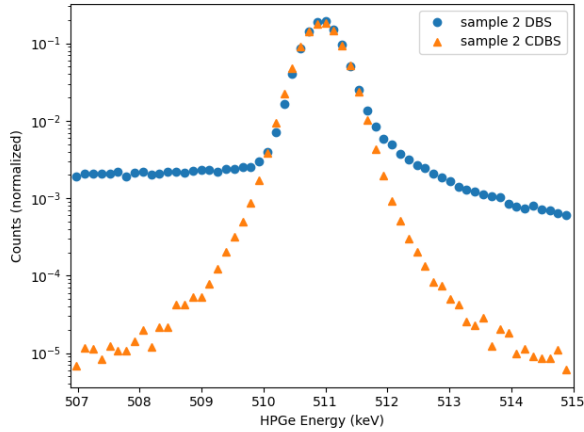

Fig. 3. Doppler broadening spectrum of PET sample measured with a single HPGe detector (blue dots) and coincidence Doppler broadening spectrum of the same sample obtained with two HPGe detectors in coincidence (orange triangle)

A self-developed Python algorithm was used to analyze DB and CDB spectra of five different polymer specimen by applying the Gaussian and parabola combined model functions[4-5]. The count spectra were normalized by the area underneath the peak curves, which were fitted with the Gaussian model.

After the Gaussian curve fitting and normalization of photon count spectrum, full width at half maximum was calculated for each Doppler shifts.

Table I: FWHM of CDBS

	Thickness ( $\mu\text{m}$ )	FWHM (keV)
Sample #1	570	5.036
Sample #2	210	5.053
Sample #3	80	5.094
Sample #4	50	5.087
Sample #5	50	5.121

## 3. Conclusions

Coincidence Doppler broadening spectroscopy system was successfully built in KAERI. The advantage of coincidence techniques is well-presented in Fig. 3; by utilizing the coincidence window, the high selectivity of the observation were acquired. The signal to noise ratio (SNR) of DB is in order of a few hundred while the SNR of CDB remains around  $10^5$ .

Despite the high resolution of CDBS technique in observing the electron momentum of the material structure, PET samples showed no distinctive difference in Doppler shift representation.

## REFERENCES

- [1] W. J. Davies and R. A. Pethrick, Positron Annihilation Lifetime and Doppler Broadening Studies of Amorphous Fluoropolymer-poly(2,2-Bis Trifluoro 4,5 Difluoro 1,3-Dioxole), European Polymer Journal, Vol.30, p.1289-1293, 1994
- [2] K.G. Lynn, J.R. MacDonald, R.A. Boie, L.C. Feldman, J.D. Gabbe, M.F. Robbins, E. Bonderup, J. Golobchenko, Positron-Annihilation Momentum Profiles in Aluminum: Core Contribution and the Independent-Particle Model, Physical Review Letters 38, p.241-244, 1977
- [3] P. Asoka-Kumar, M. Alatalo, V.J. Ghosh, A.C. Kruseman, B. Nielsen, K.G. Lynn, Increased Elemental Specificity of Positron Annihilation Spectra, Physical Review Letters, Vol.77, p.2097-2100, 1996
- [4] E. do Nascimento, O. Helene, C. Takiya, and V.R. Vanin, Doppler broadening of positron annihilation radiation: fitting the coincidence spectrum, Nuclear Instruments and Methods in Physics Research A, Vol.538, p. 723-730, 2005.
- [5] P. Pikart and C. Hugenschmidt, Novel data evaluation algorithm for Coincident Doppler Broadening Spectroscopy, Nuclear Instruments and Methods in Physics Research A, Vol.750, p.61-68, 2014.