

## Basic Design for Wobbling System of KOMAC RI Beamline Using Halbach Dipole Magnets

Yong-Sub Cho\*, Yeong Su Ha, Hyeok-Jung Kwon, Sang-Pil Yoon, Kye-Ryung Kim  
 KOMAC, Korea Atomic Energy Research Institute, Gyeongju-si, Korea  
 \*Corresponding author: choys@kaeri.re.kr

### 1. Introduction

Various RI production is planned using KOMAC 100-MeV proton beam [1]. The proton beam of Gaussian distribution made from a 100-MeV proton linear accelerator reaches the target for RI production with circular or elliptical cross sections with a diameter of several mm through a beamline consisting of dipole and quadrupole electromagnets. The target for generating RI was designed and constructed as shown in Figure 1, taking into account various factors, such as the energy and size of the proton beam. If the beam power reaching the target is less than 1 kW, it is unlikely to damage the target with a diameter of several cm or so. However, if the beam power exceeds 1 kW, the target may be damaged due to the high heat load density, resulting in the release of radioactive materials into the coolant. To prevent this, a larger beam using the beamline quadrupole magnets may reduce the high heat load density of the target center, there is a disadvantage of increasing unnecessary beam loss due to the tail portion of the Gaussian distribution

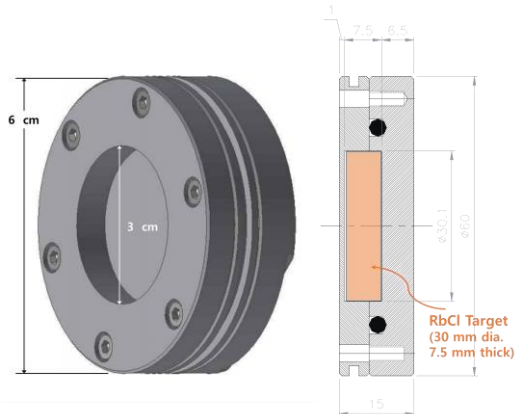

Fig. 1. RI production target

### 2. Basic Design

#### 2.1 Heat load distribution by wobbling

A method of wobbling proton beam round the target is used to reduce the high heat load density of the center, and to maintain the integrity of the target even in high beam power by minimizing unnecessary beam loss. Figure 2 shows the heat load distribution at the target by a wobbling proton beam. A larger wobbling diameter reduces the thermal load of the center, but allows for the selection of a wobbling diameter of a moderate size because of the large amount of irradiated parts other than the target. Generally, the diameter of the beam is

similar to the diameter of the wobbling. If the diameter of the beam is one-half the target diameter, it is the optimal condition to reduce the thermal load of the center and reduce the beam loss.

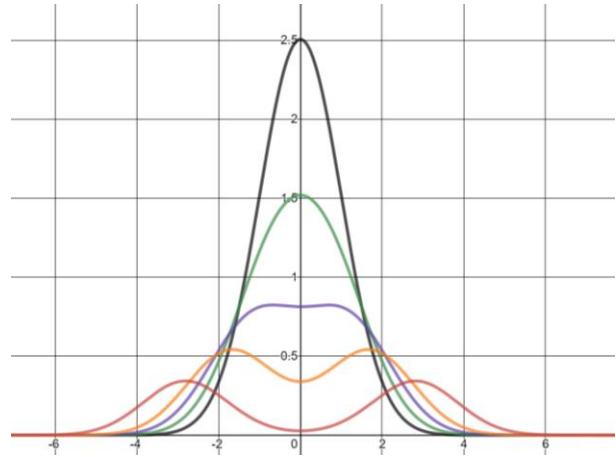

Fig. 2. Heat load distribution (black line for wobbling diameter/beam diameter = 0, green for 1, purple for 1.5, orange for 2, and red for 3)

#### 2.2 Wobbling magnet

To obtain the wobbling determined by the heat load distribution, a rotating dipole magnetic field is required. Two electromagnets whose magnetic fields are perpendicular to each other are used as a method to achieve this. However, due to the limitations of alternating current power supply, insulation voltage of the coil and coil out of the iron core, there are disadvantages of increasing size. As shown in Figure 3, since only a very limited space can be used for wobbling, KOMAC RI production beamline is intended to use Halbach dipole magnets consisting of permanent magnets for circular beam pipes that can give a large kick in a short length.

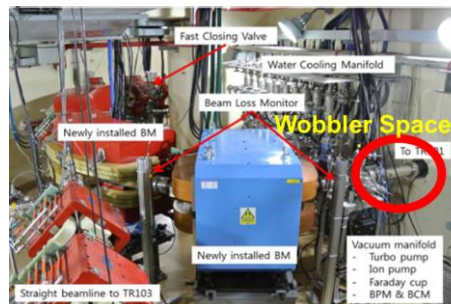

Fig. 3. KOMAC RI production beamline

Since the disadvantages of these permanent magnets are not adjustable in magnetic field, one of two methods should be chosen as shown in Figure 4 to adjust the wobbling diameter. The first is to keep the distance between the two magnets constant and change the direction of the magnetic field relatively, the second is to change the relative distance with the direction of the two magnetic fields constant. In the first case, the device is simple, but the wobbling diameter varies depending on the distance, and in the second case, the wobbling diameter is constant, but the distance between the magnets must be changed, which makes the wobblers longer.

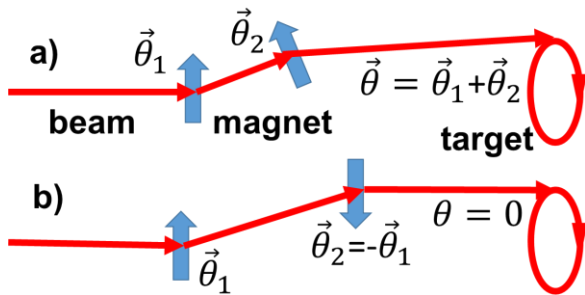

Fig. 4. Wobbling methods

### 2.3 Halbach magnet

Halbach magnet [2] is the most efficient way to generate uniform magnetic fields on a circular cross section using permanent magnets. Figure 5 shows the principle of the Halbach magnet and a picture of the magnet that will be installed in the RI beamline. The inner diameter of the magnet through which the beam pipe passes is 110 mm and the maximum magnetic field size is 5.2 kG, and the magnetic field measured at the center axis is shown in figure 6. The BL (integral of magnetic field along beam path) from the measured results is 0.0689 Tm. For 100-MeV proton, the magnetic rigidity is 1.44 Tm, so the kick angle by a dipole is 47.6 mrad (2.73 degree).

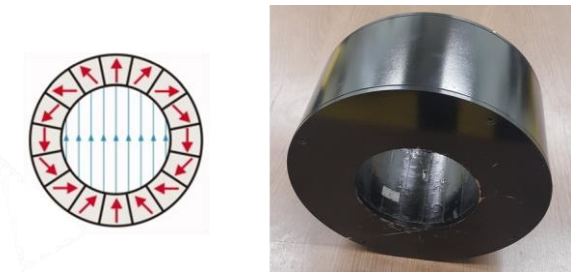

Fig. 5. Halbach magnet

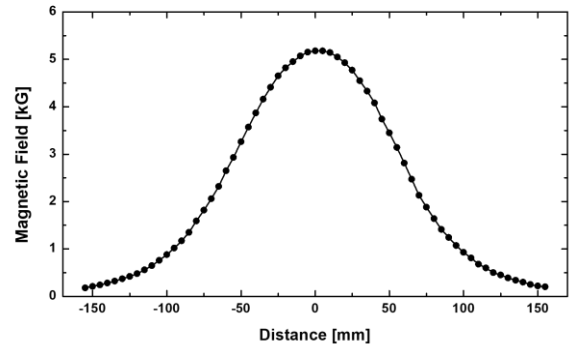

Fig. 6. Measured dipole magnetic field strength along magnet center

### 2.4 Geometry and Rotation speed of Halbach Magnets

The given space to install the wobbling system can be less than 40 cm. If the distance between the two magnets is 157 mm, the wobbling diameter is expected to be 15 mm, making it ideal for target with a diameter of 30 mm. Thus, the total length of the magnets is 267 mm, and it can be installed in a given space.

Since the repetition rate of the beam is up to 60 Hz, if the magnet is rotated at 60 rpm, 60 points around the wobbling circle will have a beam pulse. The rotation speed of the magnet was determined at 10 rpm, since the 10 beam pulses around the wobbling circle was advantageous to the mechanical device containing a motor to rotate the two magnets each weighing 20 kg.

## 3. Future Plan

After experimentally obtaining major parameters, such as beam diameter, by operating the RI production beamline, based on this design, detailed design such as rotating part by motor, fabrication and installation will be carried.

### ACKNOWLEDGEMENT

This work was supported by MSIT (Ministry of Science and ICT) and by the National Research Foundation of Korea (NRF) under Grant number NRF-2017M2A2A2A05016601 and through KOMAC (Korea Multi-purpose Accelerator Complex).

### REFERENCES

- [1] Kye-Ryung Kim, et al., "Medical RI Development Plan of KOMAC", Journal of the Korean Physical Society, Vol. 71 (2017).
- [2] Klaus Halbach, "Design of permanent multipole magnets with oriented rare earth cobalt material" Nuclear Instruments and Methods. 169 (1): 1–10 (1980).