

Novel Test Method to Measure PWSCC Initiation Time of Nickel Alloys Using Rupture Disk-type Specimen

Sung-Woo Kim *, Geon-Woo Jeon, Dong-Jin Kim

Material Safety Technology Development Division, Korea Atomic Energy Research Institute,
 Daedeok-Daero 989-111, Yuseong-Gu, Daejeon 34057, Republic of Korea

*Corresponding author: kimsww@kaeri.re.kr

1. Introduction

Nickel alloys and stainless steels, which are used as structural materials in nuclear power plants, have shown a variety of corrosion-related degradation with long-term operation. Among various corrosion behaviors, a stress corrosion cracking that occurs in the primary water coolant (PWSCC) of pressurized water reactors (PWRs), is one of the important corrosion issues, because radioactive species may leak out of a primary water when the crack grows through the pressure boundary of the main components made of nickel alloys and stainless steels. To evaluate PWSCC behavior of those alloys, various evaluation methods have been used in the past, including U-bend, reverse U-bend, and C-ring tests [1]. These methods call for materials to be removed periodically and observed after exposure to the high-temperature and high-pressure test environment. This approach has the advantage of being able to test multiple specimens at the same time, but has the disadvantage that it is difficult to determine the exact initiation time of those specimens.

In this study, a rupture disk corrosion test (RDCT) method was developed as a novel test method to evaluate the PWSCC initiation time of high corrosion resistant alloys in real-time. The test utilizes very simple and small-size test chamber, which allowing multiple tests in one primary water loop system at the same time under various conditions such as temperature, pressure, and load (stress), which is more effective than conventional experimental methods.

2. Rupture Disk Corrosion Test Method

The design concept of the RDCT method is schematically shown in Fig. 1, where the blue part is the rupture disk specimen, and the gray part is the specimen fixture. Fig. 1(a) shows the first step prior to pressurization, with the specimen fastened to the fixture. Fig. 1(b) shows, after exposure of the high-pressure side to the primary water environment (P2), in which the specimen becomes dome-shaped. Fig. 1(c) shows the moment when PWSCC initiates on the disk specimen. In Fig. 1(d), through-wall cracking or rupture occurs in the specimen, during which pressure is monitored on the low-pressure side (P1). Therefore, the initiation of PWSCC on the disk specimen surface exposed to the primary water solution at high

temperature and pressure can be easily detected due to leakage or rupture.

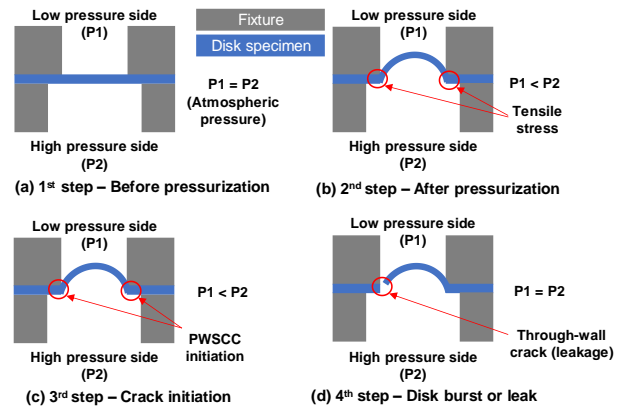

Fig. 1. Design concept of RDCT method

Finite element analysis (FEA) was performed using the ABAQUS program to predict the effective stress and deformation of the disk specimen at the site of PWSCC initiation as a function of thickness. The finite element model used for the rupture disk was 3D10 (10-node quadratic tetrahedron) with 37,781 nodes and 18,673 elements [2].

Fig. 2 gives the PWSCC initiation test loop system used to simulate typical primary water chemistry in the accelerated test condition of 360 °C and 20 MPa. The rupture disk specimens made of Alloy 600 were used in the PWSCC initiation test. The minimum thickness of the disk specimen was selected by measuring the burst pressure as a function of thickness using the loop system.

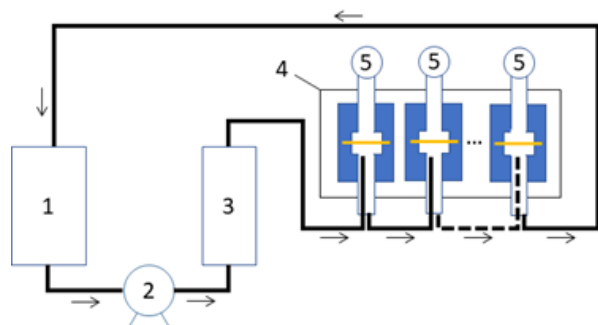

Fig. 2. Schematic drawing of PWSCC test loop, (1) primary water tank, (2) high pressure pump, (3) pre-heater, (4) main heater and (5) rupture disk corrosion test device.

3. Results and Discussion

Fig. 3 shows the FEA results for the stress distribution and deformation of the disk specimen under the test condition. It was revealed that the highest tensile stress was applied at the edge of the dome-shaped deformation part. Fig. 4 gives the maximum stress applied on the disk specimen in the high-pressure side (exposed to the primary water) as a function of specimen thickness. The applied stress decreased as the thickness of the specimen increased.

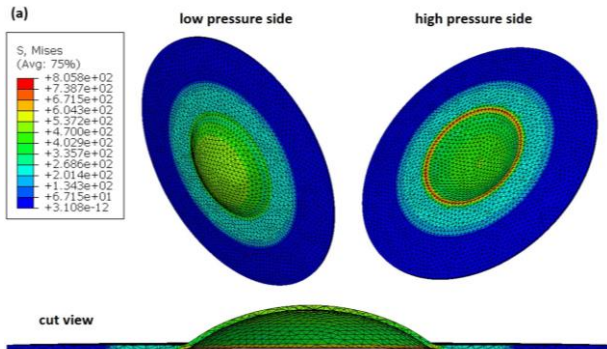

Fig. 3. FEA results for the stress distribution on the disk specimen (0.1 mm thickness).

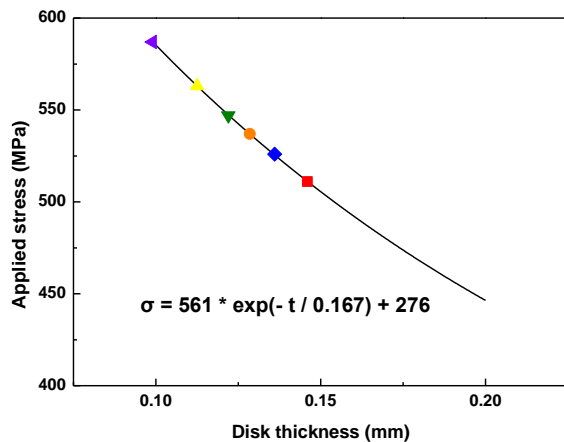

Fig. 4. Applied stress calculated from FEA as a function of the thickness of disk specimen.

The PWSCC initiation measurement was carried out from six disk specimens made of Alloy 600 with different thickness in the primary water environment using the PWSCC test loop system. Fig. 5 shows surface image of one of disk specimens of which pressure was detected to increase in the low-pressure side of the RDCT device, due to a leakage of primary water through the disk specimen. As shown in Fig. 5, typical intergranular cracks were found on the disk-specimen surface where the maximum stress was supposed to be applied (Fig. 3).

Fig. 6 presents the PWSCC initiation time measured from six disk specimens made of Alloy 600 using the RDCT. The applied stress was the maximum stress on

the disk specimen calculated from the FEA results. The PWSCC initiation time measured in this work is similar to those reported in the previous works [3]. From the test results, it was verified that the RDCT method is applicable to evaluate the PWSCC initiation time of corrosion-resistant alloys in real-time.

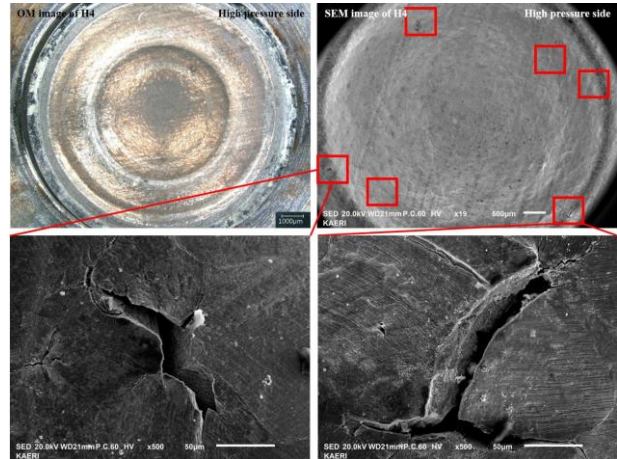

Fig. 5. Surface images of the Alloy 600 disk specimen of the RDCT device after the PWSCC initiation test.

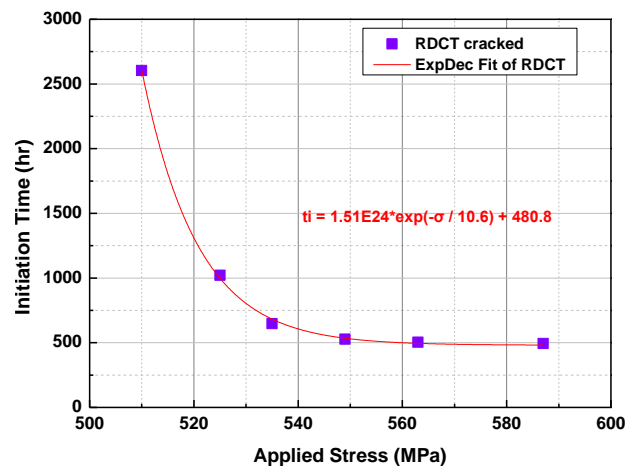

Fig. 6. PWSCC initiation time measured from the Alloy 600 disk specimens as a function of applied stress.

REFERENCES

- [1] G.H. Koch, Tests for stress-corrosion cracking, Adv. Mater. Process, Vol. 159, p. 36, 2001.
- [2] D.V.R. Murty, Finite Element Analysis of Rupture Disc, Sci. EL, Des. Eng. Div. Indian Inst. Chem. Technol. India, Tarnaka, 2006.
- [3] Z. Zhai, M.B. Toloczko, M.J. Olszta, S.M. Brummer, Stress corrosion crack initiation of alloy 600 in PWR primary water, Corros. Sci., Vol. 123, p. 76, 2017.