

Development of Design Requirements for Chemical Injection and Decomposition&Treatment Facility

JeongJu Kim*, Hak-Soo Kim and Cho-Rong Kim

KHNP Central Research Institute, 70, 1312-gil, Yuseong-daero, Yuseong-gu, Daejeon, Korea, 34101

*Corresponding author: JEONGJU.KIM@khnp.co.kr

1. Introduction

The main objective of decontamination prior to decommissioning and dismantling is reducing the radiation exposure to protect the workers, preventing the spread of contamination during dismantling and reducing the radioactive wastes. In order to perform such a system decontamination project, a decontamination technology in consideration of operation history, system materials, etc. and facility to which this technology is applied are required. Therefore, KHNP is developing a decontamination technology called CRI_RWDecom (Chemical Reagent Injection and RadWaste Decomposition&Treatment) based on organic acid [1], and a facility called CIDF (Chemical Injection and Decomposition&Treatment Facility) [2].

CIDF consists of five subsystems including a IoT-based operation control system as shown in Figure 1.

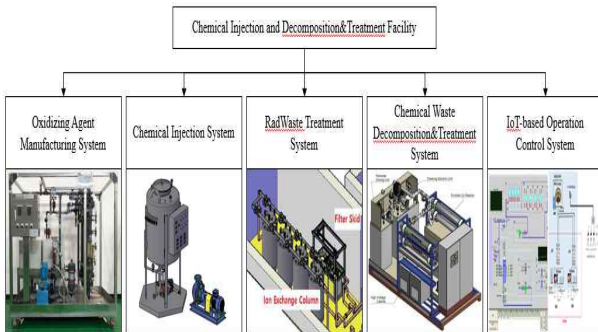

Fig. 1. CIDF system configuration diagram

This paper deals with the functions of CIDF subsystems and the design requirements of RadWaste Treatment System (RWTS) and Chemical Waste Decomposition&Treatment System (CWDS) currently being designed.

2. Functions of CIDF Subsystems

2.1 Oxidizing Agent Manufacturing System (OAMS)

This subsystem is used to product permanganic acid from potassium permanganate using cationic resin. Permanganic acid is better to use on site because the solutions are unstable, and gradually decompose into manganese dioxide, oxygen, and water [3].

2.2 Chemical Injection System (CIS)

This subject system is used to inject oxidizing and reducing agents required for system decontamination process into the primary system. Since high concentration of oxidizing and reducing agent are injected into the system piping, the impact assessment should be performed on the equipment located at the rear end of the injection location.

2.3 RadWaste Treatment System (RWTS)

This subsystem is used to remove the particulate matters and metallic ions in decontamination waste and consists of a filter and an ion exchange module. When anion exchange resin is used, the operating temperature, and cooling function must be considered.

2.4 Chemical Waste Decomposition&Treatment System (CWDS)

This subsystem is used to decompose the residual organic acid in decontamination liquid waste into H₂O and CO₂. The main component, UV reactor, must take into account limitation on operating temperature, pressure and CO₂ exhaust.

3. Design Requirements of CIDF

3.1 RWTS

The main components are filters and ion exchangers, which should be consider single failure and provide high-differential pressure alarms to inform loaded condition.

Filter can remove more than 98 % of impurities with a size of 10 μm or more, and the components must be remotely replaced. A process monitoring unit (PMU) is installed at rear end of the filter and monitors the pH, conductivity and redox potential.

In front of the ion exchanger, there should be equipment for lowering the temperature in consideration of the anion exchange resin and the temperature monitoring. The ion exchange resin can be injected from the outside of the vessel, and the spent resin can be discharged using a fluid or gas.

A differential pressure gauge is installed to monitor the pressure difference at front and rear ends, and when more than a certain amount of foreign material accumulates, a high differential pressure alarm is generated to notify the replacement time of the filter or ion exchange resin.

Valves used during filter and ion exchange resin replacement operation should consider installing a power driven or extended hand wheel to minimized exposure to workers.

3.2 CWDS

The main component is UV reactor which should be consider single failure. To satisfy the maximum allowable pressure of the UV reactor, a pressure reducing utility is required at the front end, for that reason surge tank and a separate injection pump are required. The performance of UV reactor has to meet user requirement, and it should be possible to verify it through sampling or online measuring instrument. It is also possible to consider installing separate UV lamp cleaning equipment. The detailed design of the UV reactor module is shown in Figure 2.

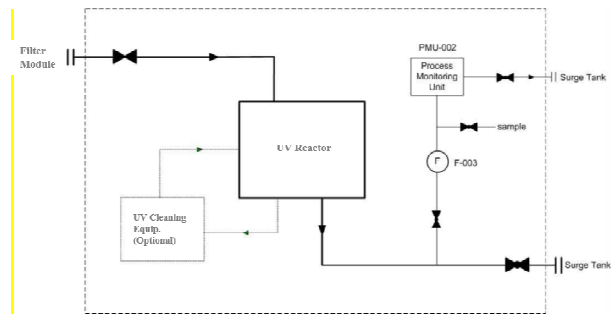

Fig. 2. Detailed design of UV reactor module

The pressure in the surge tank should be maintained at atmospheric pressure, and a cover should be installed on the top to prevent the inflow of foreign material. It is also equipped with a water level gauge to provide high and low level alarm. Tank should be protected and overflow prevented by automatically shut off inlet water when level goes high. The pump should be protected by automatically shut off the flow water when level goes low. In addition, vortex preventing device should be installed in the nozzle flowing out of the injection pump

The injection pump protects the pump by automatically stopping under the low pressure condition of the front pressure gauge and the high flow condition of the downstream flowmeter. A PMU is installed at the rear of the pump to monitor the process condition.

4. Future Plan

Based on the design requirements, which is the result of this study, the CIDF is planned to be manufactured. After that, it will be verified and used in the system decontamination project of Kori Unit 1.

ACKNOWLEDGMENTS

This work was supported by the Korea Institute of

Energy Technology Evaluation and Planning (KETEP), granted financial resources from the Ministry of Trade, Industry & Energy (Number 20191510301310)

REFERENCES

- [1] H. S. Kim, Development of Decontamination Technology of Reactor Coolant System and Dismantled Equipment for NPP Decommissioning, KHNP CRI Report, 2019-50003339-JEON-0087FR, pp. 125-127, 2019.
- [2] H. S. Kim, Development of Full System Decontamination Demonstration Technology for Light-Water Nuclear Power Plant, KHNP CRI Report, 2019-50003339-JEON-0607IR, pp. 14-17, 2020.
- [3] B. H. Greeley, A Study of the Reduction of Permanganic acid by Manganese Dioxide, Chemical Publishing Company, p. 13, 1899.