

Evaluation of Automatic Control System for Long Term Load Following Operation using Control Rod for a SMR

Kibeom Park a*, Tongkyu Park a, Sungkyun Zee a, Bon Seung Koo b

^aFNC Tech., Heungdeok IT Valley, Heungdeok 1-ro, Giheung-gu, Yongin-si, Gyeonggi-do, 446-908, Korea

^bKorea Atomic Energy Research Institute, 111, Daedeok-daero 989beon-gil, Yuseong-gu, Daejeon, 34057, Korea

*Corresponding author: kpark1026@fnctech.com

Introduction

- In order to cope with a large change in output power, a control logic using a control rod was applied to the SMR.
- Through the European Utility Requirement (EUR), it could be confirmed that the load-following operation condition required for SMRs is higher than the 48-hour level.
- It is necessary to check whether the SMR could operate normally even with the demanded load that changes frequently over a longer period of time.
- In this paper, it was confirmed that the control logic works normally through a load similar to that of the existing 48-hour demand load. And it was checked whether it was possible to operate under a random demand load and whether it was possible to operate by reflecting the demanded load for a week or a month.

Automatic Control Algorithm using Control Rod

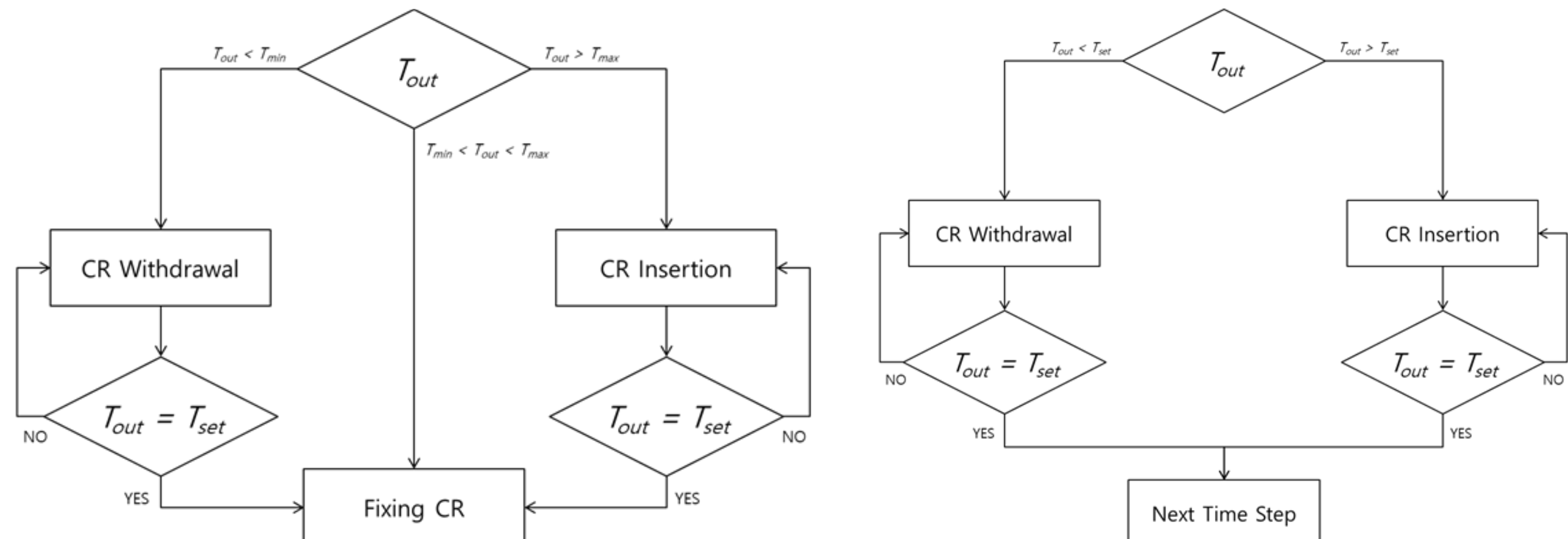

➤ Control of CRs based on Outlet Temperature Control Algorithm

➤ Control of CRs based on Setting Temperature Control Algorithm

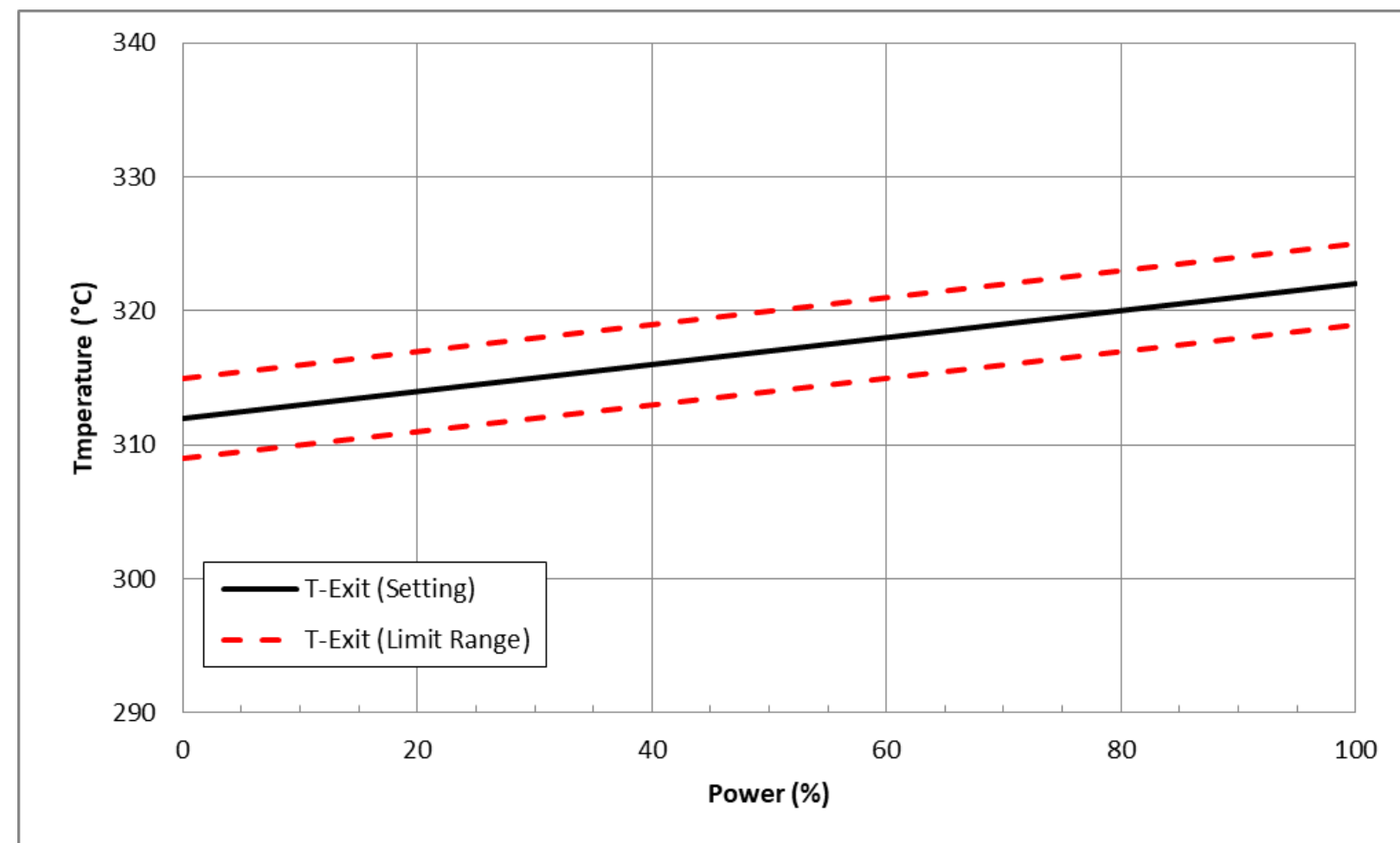

➤ Settings of Outlet Temperature Range

- Based on the coolant outlet temperature, the existing control rod insertion/withdraw algorithm that inserts/withdraws the control rod only when it exceeds the limit of the outlet temperature was analyzed.
- Temperature limit of outlet temperature was $\pm 3^\circ\text{C}$ from setting temperature.

Core Characteristic Factor Limit for a LF Operation

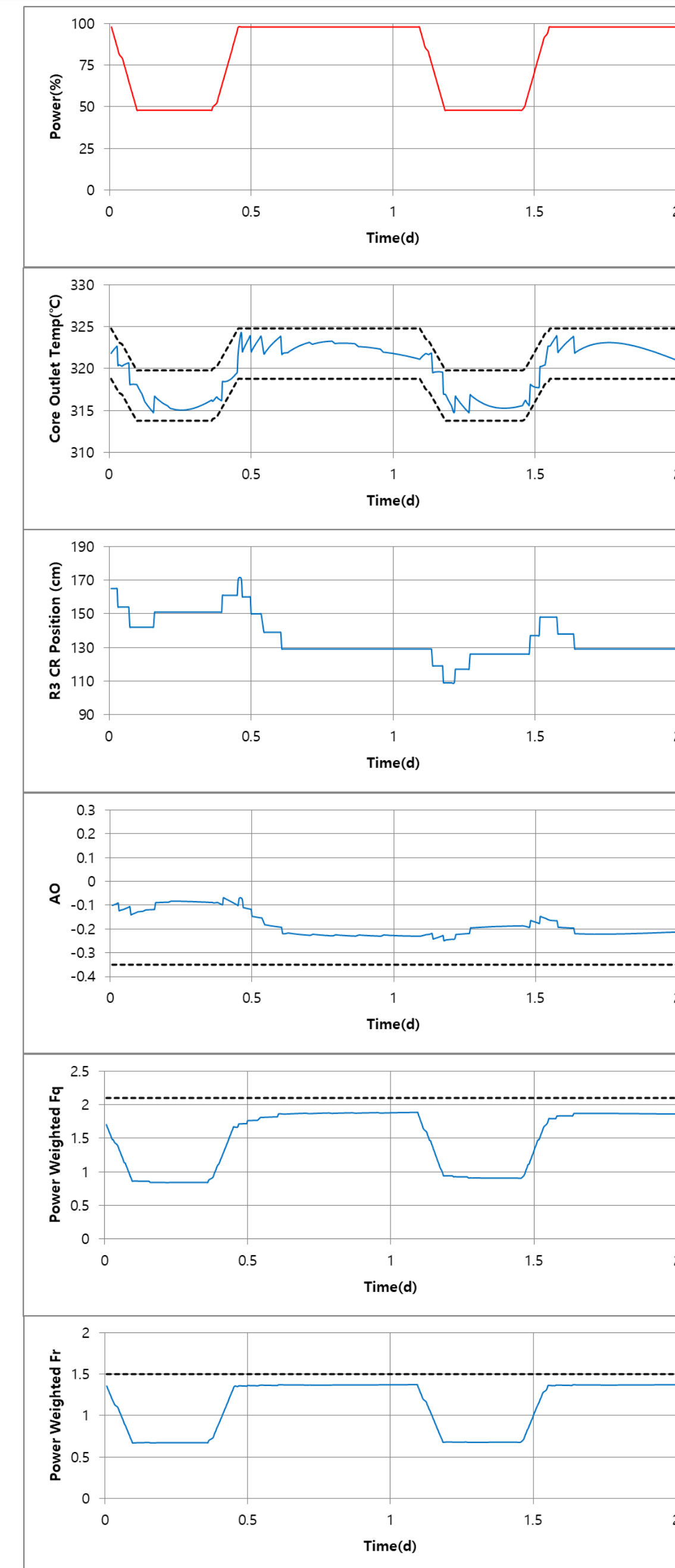

- The axial offset (AO) and the three-dimensional and two-dimensional peaking factors (F_q , F_r) were selected as the main safety variables to be considered in the load following evaluation.
- the highest priority was evaluated whether each value deviated from the safety limit during the load following evaluation.
- During the daily load follow operation, the core needs to satisfy several operating limits such as core outlet temperature, axial offset (AO), and pin peak power (F_q , F_r).
- The upper limit of peaking factor was 2.1 for F_q and 1.5 for F_r . The lower limit of AO was -0.3. The limit line for each core characteristic factor was shown in figure for each graph.
- The quasi-static calculation was used to simulate the load following calculation.
- The left figure showed the result of simple quasi-static calculation with load following calculation with MASTER code

- Core characteristics factor to be considered when evaluating the LF

Analysis Results and Conclusion

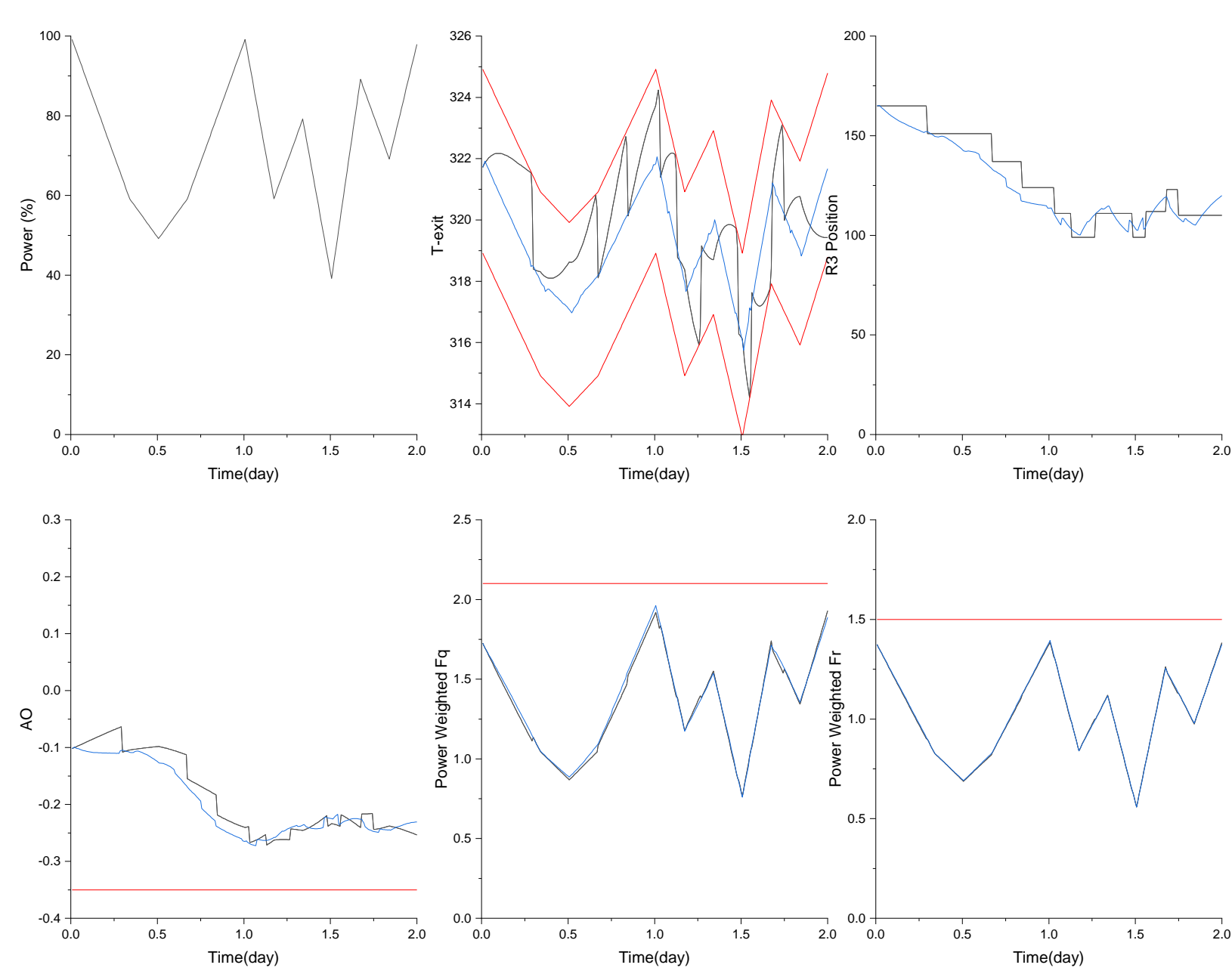

▪ Load Following Operation Core Characteristic Factor at BOC condition

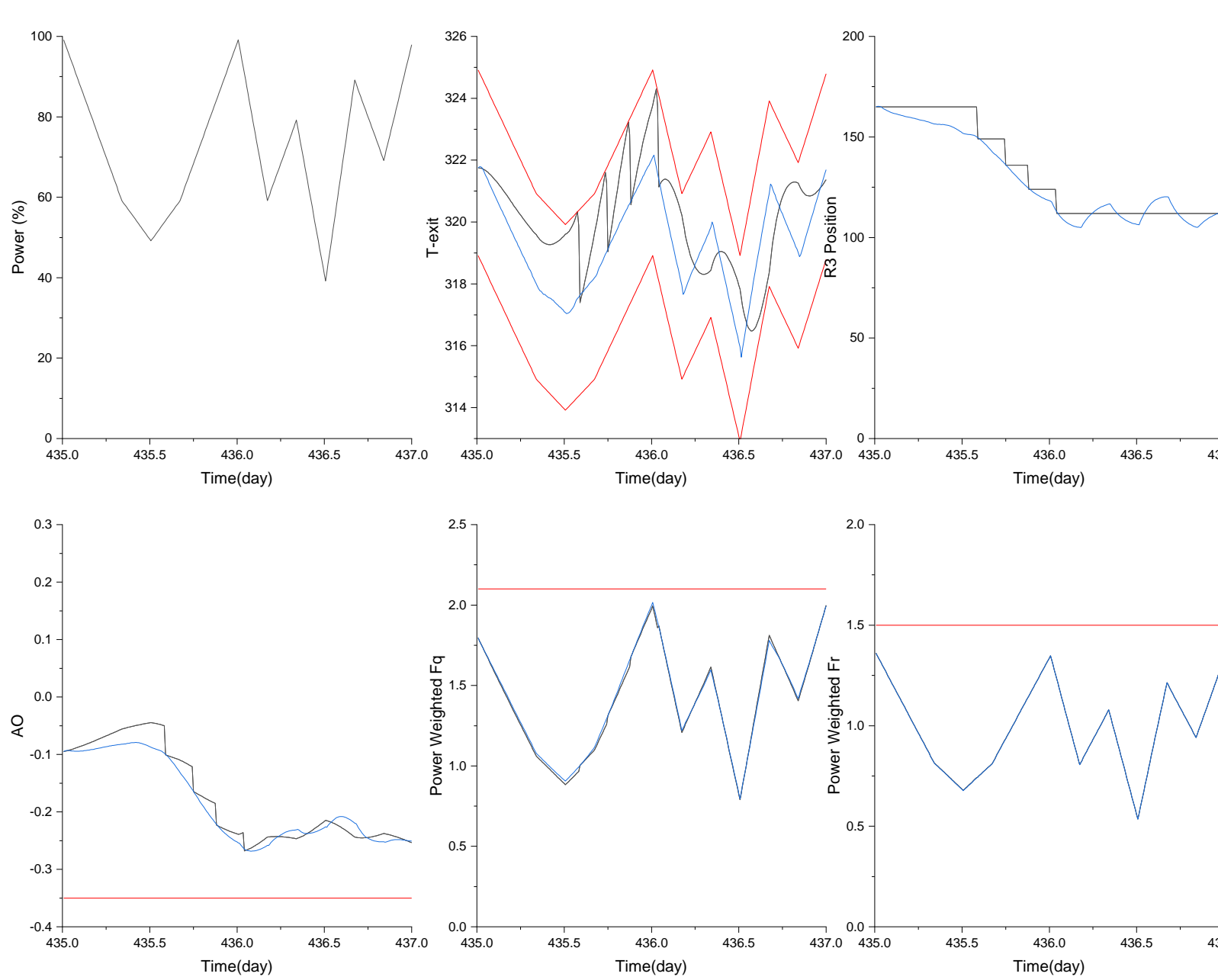

▪ Load Following Operation Core Characteristic Factor at MOC condition

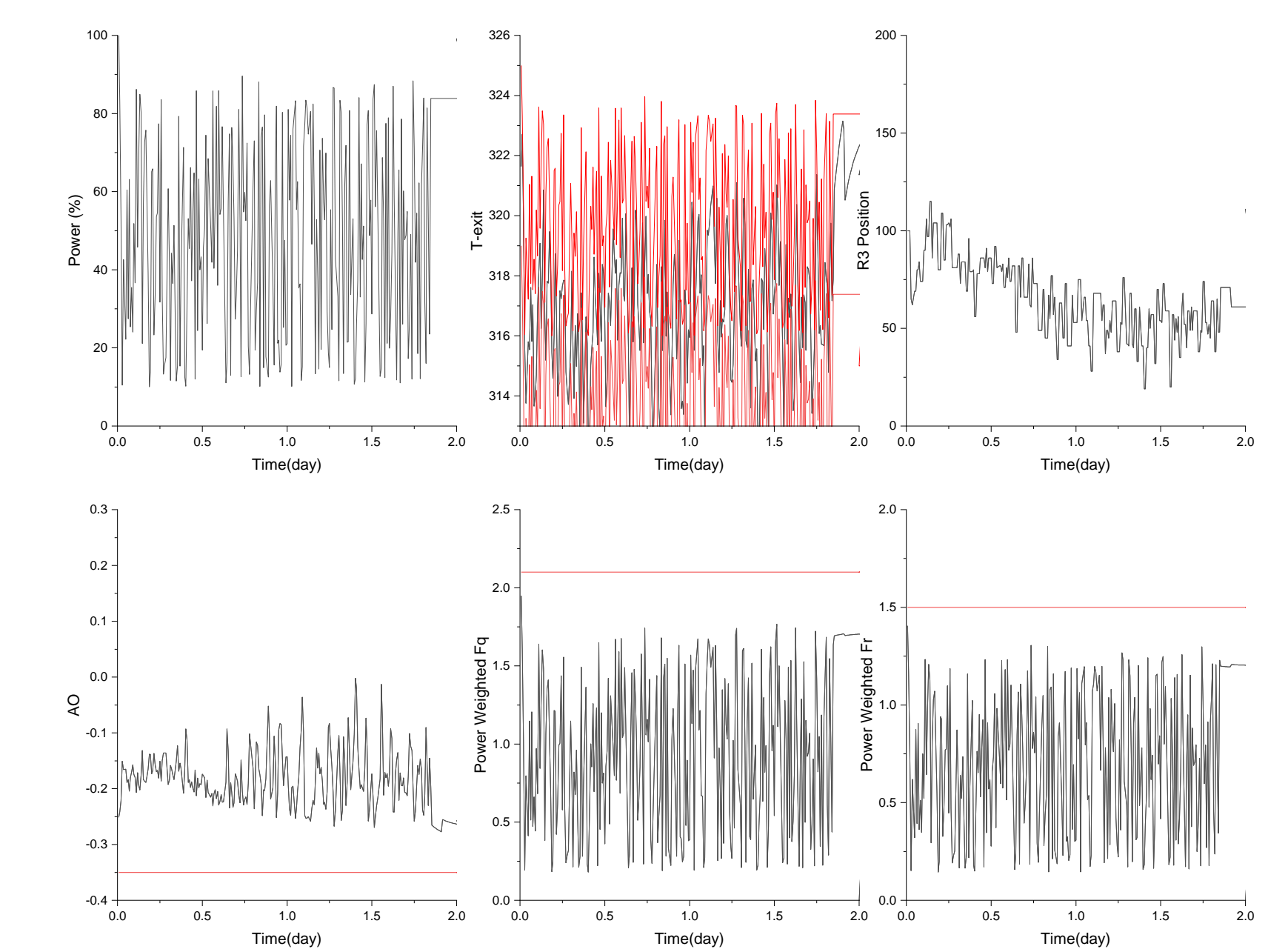

▪ Load Following Operation Core Characteristic Factor with random demand load (large)

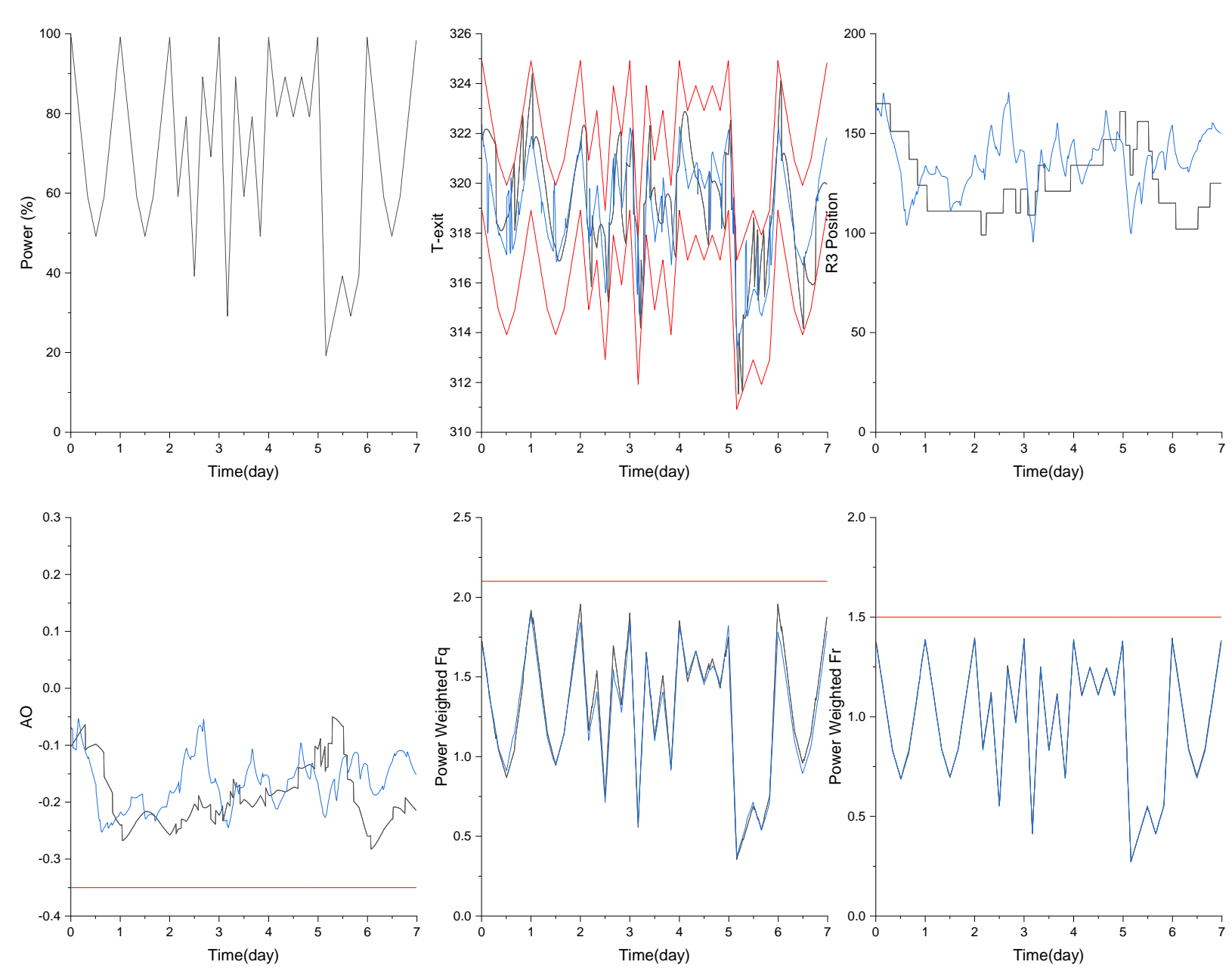

▪ Load Following Operation Core Characteristic Factor with weekly demand load

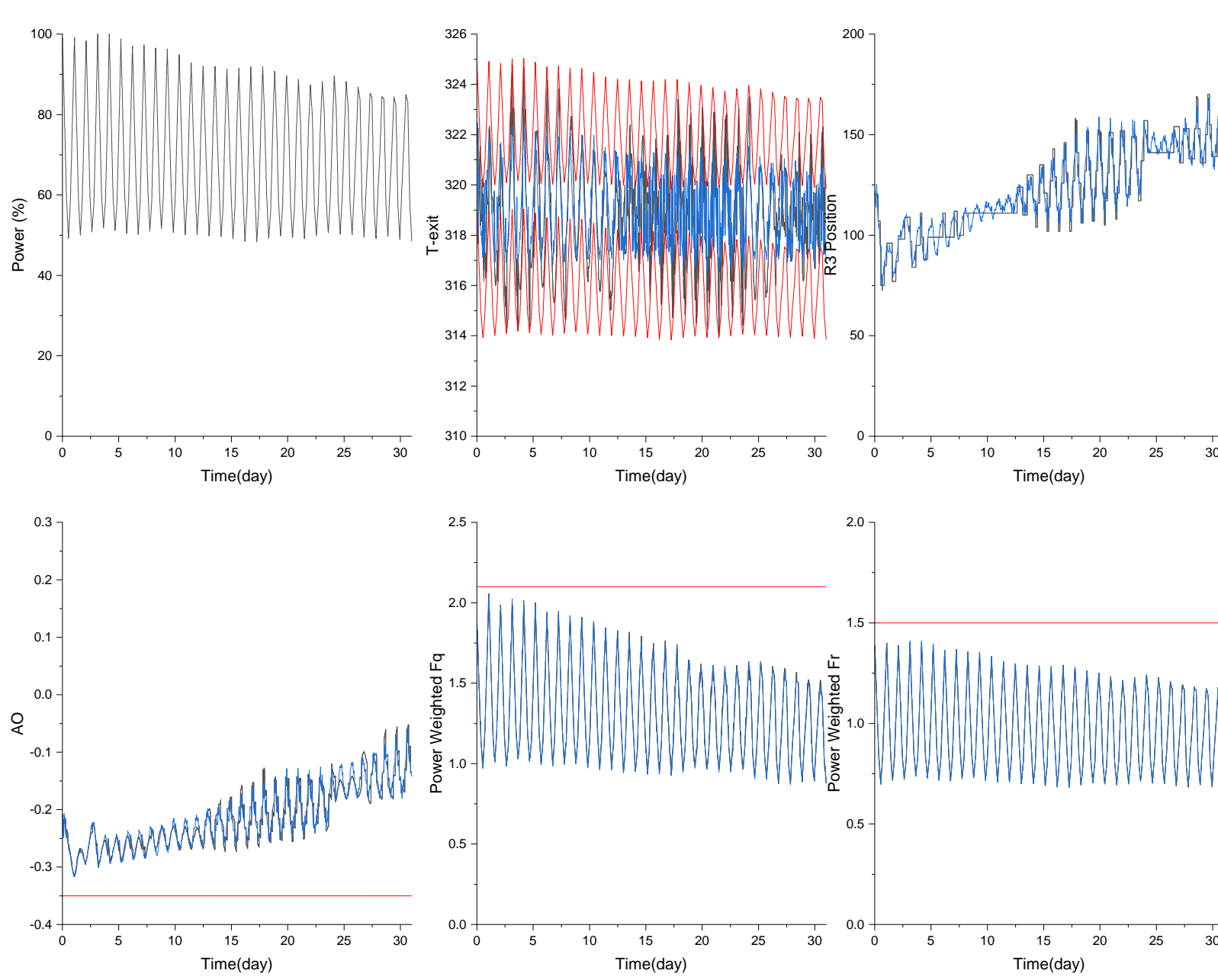

▪ Load Following Operation Core Characteristic Factor with monthly demand load

- The evaluation of load following was performed with the core design code (MASTER) and preliminary evaluation was performed with various load demand.
- Firstly, comparative calculations were performed at the BOC, MOC, and EOC by the automatic CR control algorithm with the core demand load. And the BOC and MOC results were showed in this poster.
- Secondly, comparative calculations were performed by the automatic CR control algorithm with the random demand load.
- Finally, comparative calculations were performed by the automatic CR control algorithm with the weekly and monthly demand load.

Summary

- Showed the feasibility of load follow operation by adjusting the regulating bank at BOC, MOC, EOC and random load demand.
- Additionally the weekly and monthly core simulation was performed.
- For the entire simulation, the core characteristic factor was satisfied with limit range.