

A Feasibility Study on the Application of Additive Manufacturing Method to Fabricate Nuclear Fuel using Surrogate

Jae Ho Yang*, Dong Seok Kim, Heung Soo Lee, Dong-Joo Kim, Ji-Hae Yoon
KAERI, 111 Daedeok-daero 989beon-gil, Yuseong-gu, Daejeon, 34057, Korea

* Corresponding author: yangjh@kaeri.re.kr

1. Introduction

With the progress of additive manufacturing technology, studies are actively underway to apply this technology to the manufacture of components of nuclear power plants [1-4].

In this preliminary study, we assessed the feasibility of additive manufacturing method (3D printing) to fabricate nuclear fuel pellets in oxide form using surrogate materials. We also briefly discussed the technical challenges to successfully implement this advanced technique in manufacturing of ceramic nuclear fuel components.

2. Additive Manufacturing for Ceramic Pellets

In general, ceramic materials such as oxides or carbides have high melting temperatures and tend to decompose or reduce at high temperature depending on the atmosphere. The solid form of ceramics is fabricated by the sintering process which is accompanied by heating the green pellet below the melting temperature of materials. Therefore, there are difficulties to apply a method of depositing layers of melt using high energy beam, such as L-DED or L-PFB, for additive manufacturing of ceramics. Additive manufacturing methods of stereo-lithography using UV laser or binder jet are being studied to fabricate ceramic materials with complex geometries. In fact, since both methods provide interim products consisting of ceramic powder and organic resin, post processes of calcination and sintering are essential to fabricate final ceramic products having desired density and purity.

Fabrication trials of silicate objects have been conducted using a commercially available resin 3D printer (IMC, Carima) that utilizes digital light printing (DLP) technology with UV wavelength of 405nm, and a commercially available UV-curable porcelain resin (CCTP17W, Carima).

Fig. 1 shows the design of ceramic model samples developed using CAD program. These model shapes are copied in the 3D printers and supporting structure for printing is produced automatically using the commercial program imbedded in the 3D printer. A cylindrical pellet was divided in to two parts as shown in Fig. 1 and those parts were printed using resin 3D printer.

Fig. 2 shows the fabricated objects. The ceramic objects were successfully manufactured and the dimensional tolerance was within acceptable range. The trial samples have inner empty spaces and complex

shape inside, making it difficult to fabricate by conventional methods. However, it was able to easily and successfully manufacture it using porcelain resin 3D printing.

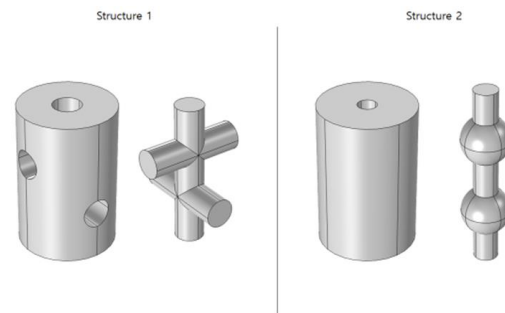

Fig. 1. Sample designs for fabrication trials of ceramic objects. Cylindrical pellets were divided into two parts, and total 4 parts of objects were fabricated by additive manufacturing.

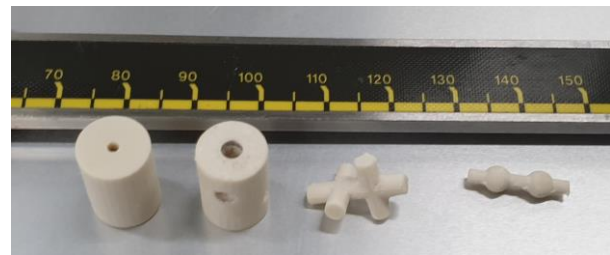

Fig. 2. Trial ceramic samples after resin 3D printing and support removal.

The printed objects were fired to remove chemical resin and increase the density. The samples were heated to 1000 °C with the heating rate of 2K/min and hold for 30 min. Two kinds of firing gas have been applied to test the effect of firing atmosphere on the removal of resin. Fig. 3 shows the trial samples after firing under inert Ar atmosphere. The samples after firing show black color indicating the chemical resin was not completely decomposed nor removed from the samples. Fig. 4 shows the shape of samples which were annealed under air. The samples show white color revealing that the resin was completely burned and removed.

In UO₂ sintering process, the sintering should be conducted under reducing atmosphere to avoid the oxidation of UO₂. The UV-curable resin used in this trials is not suitable for the manufacture of UO₂-base nuclear fuel because it does not fully decompose in an inert atmosphere and remains in the specimen. It is

necessary to develop resins that are easily decomposed and vaporized at low temperatures in an inert or reductive atmosphere.



Fig. 3. Trial ceramic samples after firing under inert Ar atmosphere.



Fig. 4. Trial ceramic samples after firing under oxidative air atmosphere.

Figs. 3 and 4 show that cracks were developed throughout the structure that run parallel and normal to the build-up layers. These cracks may be formed due to the resin burnout or the residual stress induced by heterogeneity in ceramic power distribution, or sequential polymerization of resin.

3. Conclusions

Additive manufacturing using DLP methods demonstrates the possibility of manufacturing nuclear fuels of various structures without restriction on fuel geometry. However, to obtain the desired quality of nuclear fuel, it is necessary to develop technologies to address various technical issues such as the resin system that is easily decomposed in the reducing atmosphere, optimization of process to suppress defect formation in the sintered body, and management of bi-product of carbon-containing gases.

Acknowledgments

Funding: This work was supported by the National Research Foundation funded by Ministry of Science and ICT of Korea (grant number 2017M2A8A5015056).

REFERENCES

- [1] A. Bergeron, J.B. Crigger, Early progress on additive manufacturing of nuclear fuel materials, *Journal of Nuclear Materials* 508 (2018) 344-347, <https://doi.org/10.1016/j.jnucmat.2018.05.058>
- [2] A. T. Nelson, Features that further Performance Limits of Nuclear Fuel Fabrication: Opportunities for Additive Manufacturing of Nuclear Fuels, ORNL/SPR-2019/1183
- [3] Michael P. Trammell, Brian C. Jolly, M. Dylan Richardson, Austin T. Schumacher, Kurt A. Terrani, Advanced Nuclear Fuel Fabrication: Particle Fuel Concept for TCR, ORNL/SPR-2019/1216
- [4] Suk Hoon Kang, Joowon Suh, Sang Yeob Lim, Seungmun Jung, Young Woon Jang, In Soo Jun, Additive manufacture of 3 inch nuclear safety class 1 valve by laser directed energy deposition, *Journal of Nuclear Materials* 547 (2021) 152812, <https://doi.org/10.1016/j.jnucmat.2021.152812>