

## Thermal aging effects of CF-3 cast austenitic stainless steel studied by positron annihilation lifetime spectroscopy

Jaegi Lee<sup>a</sup>, Jongbeom Kim<sup>b\*</sup>, Young Su Jeong<sup>a</sup>, Young Rang Uhm<sup>a</sup>, Gwang-Min Sun<sup>a</sup>, Sung-Sik Kang<sup>c</sup>, Jin-Gyem Kim<sup>c</sup>

<sup>a</sup>HANARO Utilization Division, Korea Atomic Energy Research Institute, Daejeon, 34057, Republic of Korea

<sup>b</sup>Materials Safety Technology Development Division, Korea Atomic Energy Research Institute, Daejeon, 34057, Republic of Korea

<sup>c</sup>Department of Nuclear Safety Research, Korea Institute of Nuclear Safety, Daejeon, 34142, Republic of Korea  
E-mail: jkim8@kaeri.re.kr

### 1. Introduction

Cast austenitic stainless steels (CASS) are widely used in light water reactors. The CF-3 is one of the common CASS alloys, equivalent to 304L wrought stainless steels, and is often applied in pump casings, valve bodies, piping, and elbows in cooling systems. However, thermal embrittlement by the cleavage of the ferrite phase or the precipitation of carbides in the austenite phase boundaries can be structural safety issues for long-term operation [1]. Thermal aging at 290-400°C induces microstructural evolution: spinodal decomposition, precipitation of G-phase particles, and co-precipitation of Cu-rich clusters [2].

Positron annihilation lifetime spectroscopy (PALS) has an advantage of defect analysis due to the atomic-scale sensitivity in vacancies, defects, or dislocations. It is widely used in the non-destructive test in solid-state physics. PALS can describe the microstructural change in thermal aging process.

In this study, the thermal aging effects of CF-3 CASS alloy were analyzed by PALS.

### 2. Materials and Methods

Thermally-aged and unaged CF-3 CASS alloys were examined in this study. The CF-3 CASS alloy samples were summarized in Table 1. Each sample was thermally aged at different temperature and aging time. The chemical composition (wt%) of CF-3 was Fe-20.22Cr-7.58Ni-0.19Mo-1.93Si-1.44Mn-0.35Cu-0.17Co-0.05P. Carbon was contained in 1,196 atom ppm.

Table 1: CF-3 cast austenitic stainless steel (CASS) alloy samples

Aging time Temp.	1.5 kh	10 kh	30 kh
Room	#1		
290°C	#2	#5	
330°C	#3	#6	#9
360°C	#4	#7	#10
400°C		#8	

For positron annihilation lifetime spectroscopy, a 20- $\mu$ Ci Na-22 positron source was encapsulated in a 2.5- $\mu$ m thick nickel foil. The size of the positron source was 8  $\times$

8 mm<sup>2</sup>. The time difference between the 1.27 MeV  $\gamma$ -rays simultaneously emitted by the positrons from the beta decay and the 0.511 MeV annihilation  $\gamma$ -rays was measured by the two BaF<sub>2</sub> scintillators (Fig. 1). A 1-mm nickel foil was added on the opposite site of the CF-3 sample because the positrons should be annihilated in the sample and source materials, which the positron lifetime was well-known.

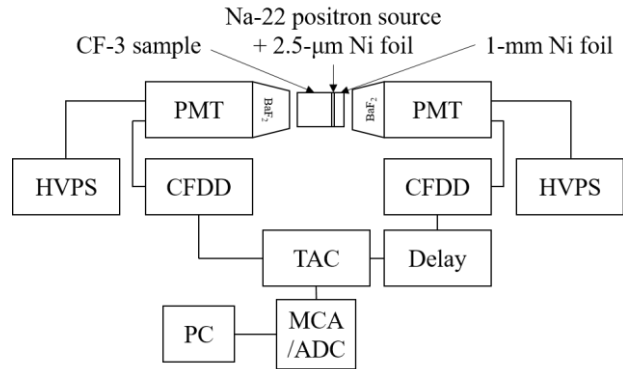

Fig. 1. Schematic diagram of positron annihilation lifetime spectroscopy

The instrumental time resolution was decided by the measurement of 1.173 and 1.332 MeV  $\gamma$ -ray from Co-60 point source. The time-to-amplitude converter (TAC) collected the time difference events of two  $\gamma$ -rays within 50 ns, and the multi-channel analyzer (MCA) was set to 4,096 channels so that the channel width was 12.2 ps/channel. Each positron lifetime spectrum was collected in 80,000 s.

The positron lifetime spectrum was unfolded into the three lifetime components using the *PALSfit3* software. The source correction was included by the positron lifetime measurement of nickel foils. The shortest lifetime ( $\tau_1$ ) comprises annihilation from the free state. The lifetime  $\tau_2$  represents the positrons trapped at defects. The largest lifetime ( $\tau_3$ ) contains the positronium component annihilated at the salt in the positron source. The positron lifetime spectrum can be expressed in the following equation:

$$y(t) = R(t) \otimes \sum_i I_i e^{-t/\tau_i} + B$$

, where  $R(t)$  is the instrumental resolution function of the detection system,  $I_i$  is the intensity of positron lifetime

component  $i$ ,  $\tau_i$  is the positron lifetime of component  $i$ , and  $B$  is background.

The mean lifetime ( $\tau_m$ ) can be calculated by the following equation:

$$\tau_m = \tau_1 I_1 + \tau_2 I_2 + \tau_3 I_3$$

, where  $I_i$  is the intensity of the lifetime  $\tau_i$ .

### 3. Results and Discussion

The positron annihilation lifetime spectrum and the unfolded positron lifetime spectra of the sample #10 was shown in Fig. 2. The chi-square values of each unfolding process between raw and unfolded spectra were less than 2. The positron mean lifetime was shown in Fig. 3. The mean lifetime was decreased as the thermal aging time increased. Also, the higher the thermal aging temperature, the shorter the mean lifetime. Until 400 °C, the defects or dislocations in the CF-3 CASS alloy were reduced by thermal aging.

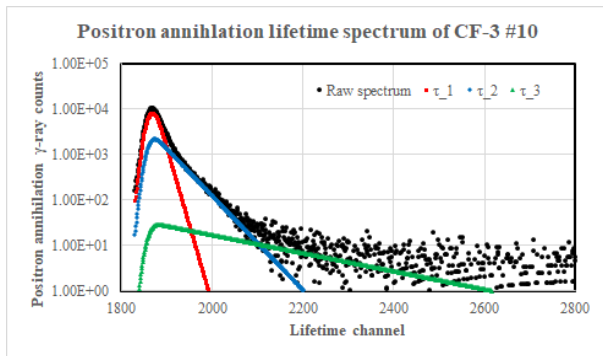

Fig. 2. Positron annihilation lifetime spectrum and unfolded positron lifetime spectra of CF-3 #10 sample

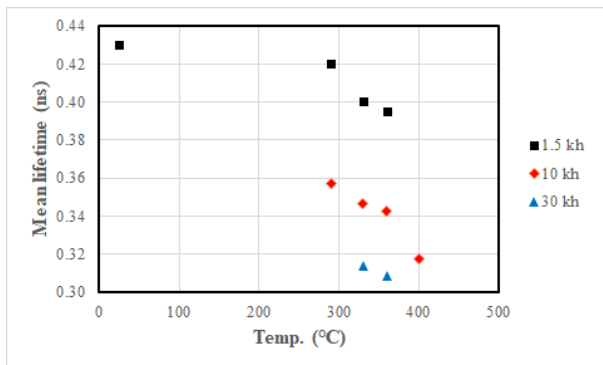

Fig. 3. Positron mean lifetime ( $\tau_m$ ) of CF-3 cast austenitic stainless steel (CASS) alloys

### 4. Conclusions

In this study, we analyzed the defect or dislocation of the CF-3 CASS alloys using PALS. The positron mean lifetime of the CF-3 CASS alloys was inversely proportional to the thermal aging time and temperature. Up to 400°C, thermal aging may not damage the CF-3 CASS alloys.

### ACKNOWLEDGEMENT

This work was supported by Radiation Technology R&D program through the National Research Foundation of Korea funded by the Ministry of Science and ICT (NRF-2017M2A2A6A05018529).

### REFERENCES

- [1] J. Kim, J. Kim, B. Kong, K. Kim, C. Jang, S. Kang, and K. Jhang, Applicability of nonlinear ultrasonic technique to evaluation of thermally aged CF8M cast stainless steel, Nuclear Engineering and Technology, Vol. 52, No. 3, pp. 621-625, 2020.
- [2] T. G. Lach, A. Devaraj, K. J. Leonard, and T. S. Byun, Co-dependent microstructural evolution pathways in metastable  $\delta$ -ferrite in cast austenitic stainless steels during thermal aging, Journal of Nuclear Materials, Vol. 510, pp. 382-395, 2018