

# Analysis of the Contact Surface Reaction of the APR1400 Steam Generator Support

Seungkyum Kim <sup>†</sup>, Ihn Namgung <sup>\*</sup>  
<sup>†\*</sup> KEPCO International Nuclear Graduate School (KINGS)  
<sup>†</sup> Corresponding author: [skkim@kings.ac.kr](mailto:skkim@kings.ac.kr)

## 1. Introduction

The APR1400 Reactor coolant system (RCS) model was developed as a lumped mass and beam model as shown in Fig. 1. So it is difficult to evaluate support system load clearly and it is not suitable for analyzing such purpose. In this study, we developed the APR1400 RCS 3D solid model taking into account the geometric symmetry. This model was used to assess the RCS internal stresses coming from operational mode changes and fluctuations. The results revealed and confirmed that steam generator (SG) nozzle region experiences highest stresses <sup>[1]</sup>.

In this study, based on the APR1400 3D model developed previously we refined the model and analyzed SG support stress in detail. The study focused on the variation of contact stress and area of the SG support system according to the change of operating condition. This kind of calculation is not possible by the APR1400 RCS model shown in Fig. 1.

With detailed SG support system analysis we can assess the peak stress level that will eventually determine the life of SG support pad. In particular, the stress concentration areas and distributions were calculated in detail for the first time. We can utilize the result to further optimize the SG support system.

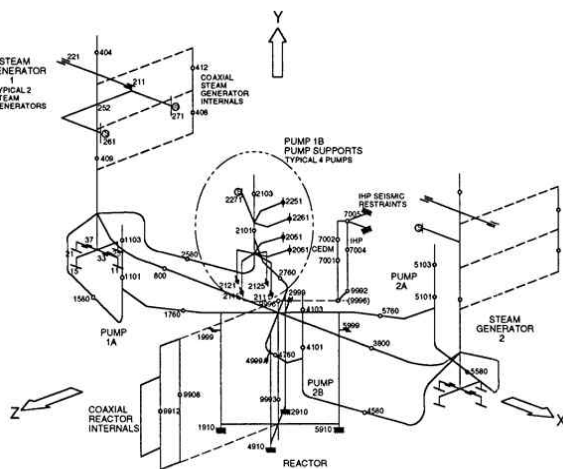

Fig. 1 APR1400 RCS seismic analysis model

## 2. Methods and Results

This section describes the modeling and meshing methodologies, boundary conditions, load conditions, material properties, and analysis the results.

### 2.1 Modeling and Meshing methodology

APR1400 RCS was modeled by using CATIA 3D CAD software. Design details such as the CVCS system and the pressurizer (PZR) were ignored and any assembly details such as round and chamfer were ignored as well to simplify modeling. The reason we did not include CVCS system and PZR is they are connected to RCS main pipe via smaller bore pipe and any deformation in the CVCS or PZR are absorbed by the connected pipes and do not impose significant load to the RCS system.

Since the full RCS model is too big and is not necessary, we simplified the model by taking advantage of RCS symmetry. Fig. 2 shows a quarter model of full RCS. We considered only symmetry loading that include pressure and temperature loads, hence we can simplify the RCS full model to a quarter model. Fig. 2 shows a quarter 3D model of RCS viewing from front and back.

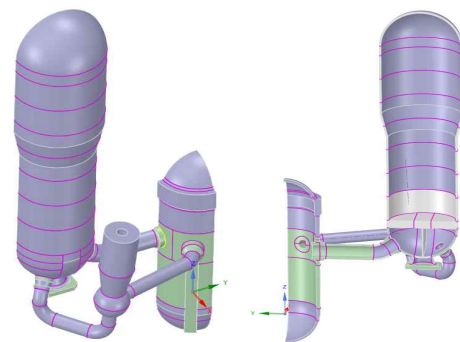
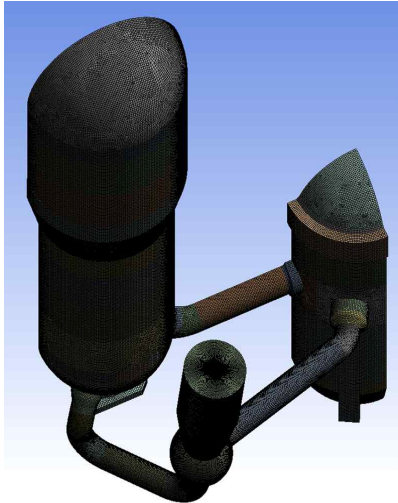

Fig. 2. RCS Design

The RCS 3D model shown in Fig. 2 was still very complicated to do default mesh and get all hexahedral elements. To achieve meshing based on hexahedral elements, we divided the RCS 3D model into small pieces and created a high-quality hexahedral mesh. Fig. 3 shows

the mesh results of the RCS model of Fig. 2. A meshed model of the quarter model of RCS is given in Fig. (3). Fig.3 (a) shows full view of RCS meshed model, and (b) shows Reactor Vessel (RV) meshed model and (c) shows SG meshed model where the left side figure is a view from outside and the right side figure is a view from inside.



(a) RCS meshed model

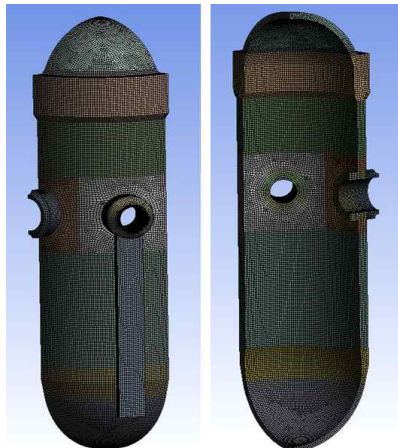

(b) RV meshed model



(c) SG meshed model

Fig. 3. RCS meshed model

Detailed view of nozzle areas where meshing was difficult show all hexahedral element mesh. Fig. 4 (a) shows detailed view of RV cold-leg nozzle area, (b) for RV hot-leg nozzle area and (c) for Reactor Coolant Pump (RCP) nozzle areas and (d) for SG nozzle areas.

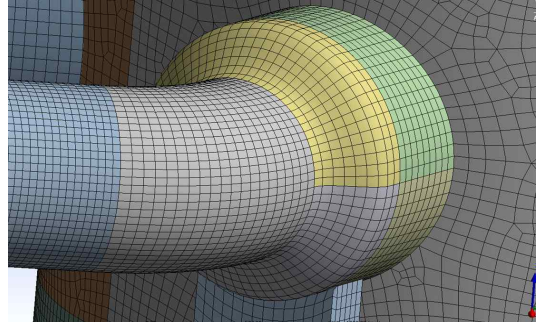

(a) RV cold-leg area detailed meshes

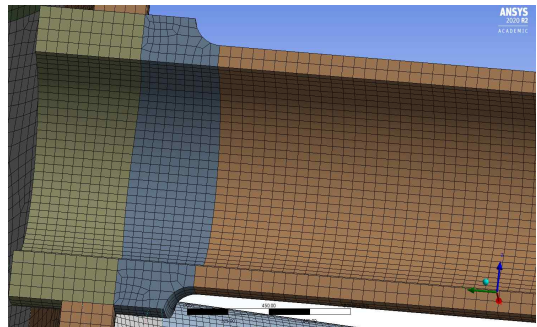

(b) RV hot-leg area detailed meshes

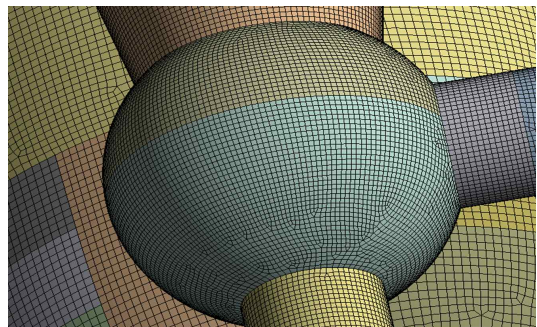

(c) RCP detailed meshes

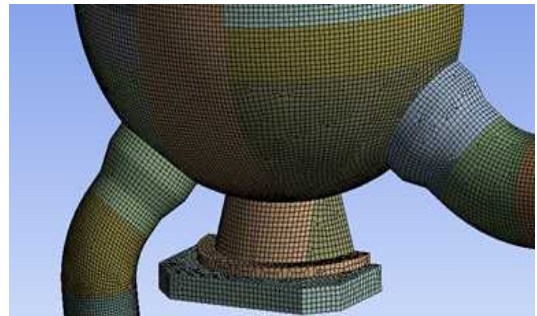

(d) SG support and nozzle area detailed meshes

Fig. 4. Detailed view of RV, RCP and SG nozzle areas

The total number of nodes is around 1.17million and the total number of elements is around 3.33million. The

total number of nodes and elements are highly dependents on how to mesh. It is desirable to make hexahedral mesh to get lower number of nodes and elements and get more accurate solution.

A enlarged figure of SG and sliding base are shown in Fig 5. The sliding base contact with SG support skirt. This is the area we are investigating in this study for any variations in contact stress and contact area.

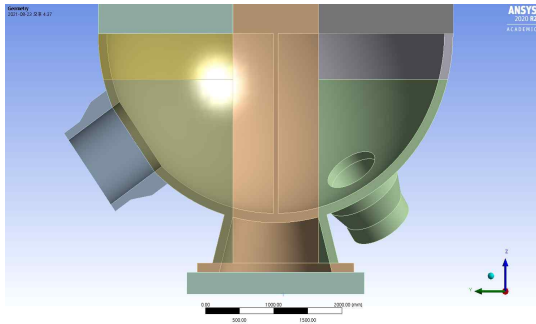

Fig. 5. SG - Sliding base, Fixed support

## 2.2 Support Modeling and Boundary Conditions

A fixed support boundary condition was imposed on the support column and fixed base of the SG. Fig 6 and 7 are attached below.

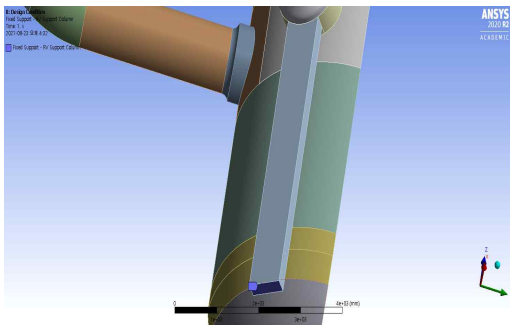

Fig. 6. RV Support column – Fixed support

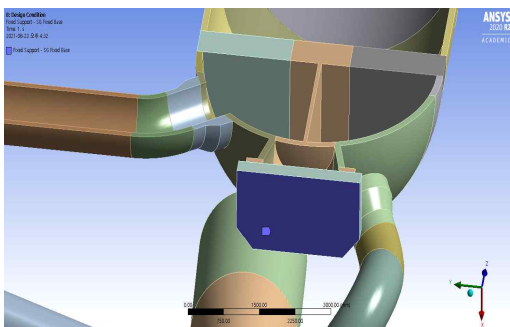

Fig. 7. SG Fixed base – Fixed support

Frictional contact boundary condition was applied between the sliding base and the fixed base of the SG. Fig 8

shows fixed base and image of support skirt.

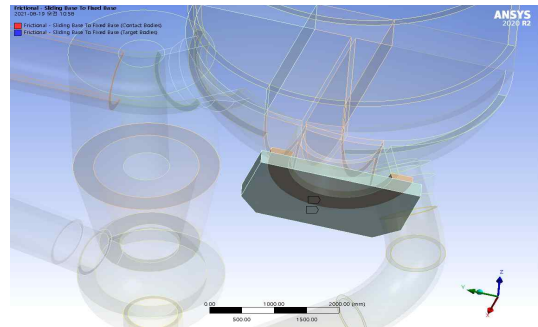

Fig. 8. Enlarged view of frictional contact

In addition, there is a horizontal snubber in the upper part of the SG. All of the symmetry surface s of the model were assigned a frictionless support condition. This condition is possible only for the symmetry loading cases as explained previously. If the input loading is not symmetry, then the deformation will break the symmetry condition. Hence, symmetry model of RCS becomes invalid.

## 2.3 Material Properties and Loading Conditions

The APR1400 RCS material is made of SA-508 and the details of the material properties were obtained from ASME BPVC Section II. Fig. 9 shows ANSYS material input screen.

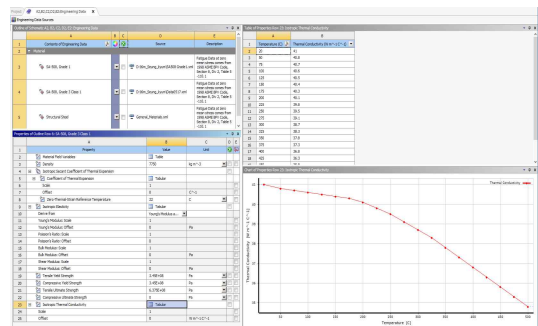

Fig. 9. Material specification in ANSYS

For the weight of the internal structure, the internals design model was used to get the weight in SpaceClaim.

In addition to the component weights, consideration of water is necessary. The empty space of RCS inner space can be calculated from CAD data. For each component, the water volume of components were calculated.

The temperature and pressure are different depending on the reactor operation state. The outside surface of RCS is assumed as insulated. The temperature and pressure according to each analysis are as follows.



- 1) Installed condition
  - There is no water in the system.
  - Temperature : 68 °F (20 °C)
  - Pressure : 14.696 psi
- 2) Shut-down condition
  - The system contains water.
  - Temperature : 68 °F (20 °C)
  - Pressure : 14.696 psi
- 3) Normal operating condition
  - Temperature : The temperature for each part was given separately.
  - Pressure: Primary Side 2250 psi  
 Secondary Side 1000 psi
- 4) Design condition
  - Temperature : 650 °F (343.33 °C)
  - Pressure : Primary Side 2500 psi  
 Secondary Side 1200 psi

## 2.4 Results and Discussion

This study investigated in detail the SG support behavior and distribution of stress concentration at the point where the sliding base and the fixed base of the SG contact each other in different states of operating condition.

Figures 10~13 shows the contact pressure at the contact surface. Because SG is very heavy equipment, it has been considered that the interface between SG support and sliding base would be in complete contact. However, the simulation showed different result than predicted. The contact surfaces are not uniform due to the deformation of SG support skirt. This may indicate the thickness of SG support skirt may not be thick enough.

Figures 10 and 11, at the installed condition and shut-down condition, the contact pressure is higher towards the center line of the SG. There is a little difference in the contact area for installed condition and shut-down condition, Fig. 10 and 11, however, the contact pressure increase for shut-down case due to dead weight of water.

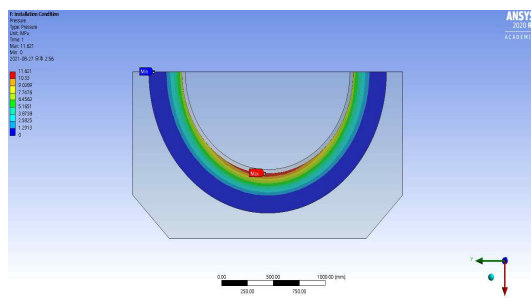

Fig. 10. Installed condition (Max. press. : 11.621 MPa)

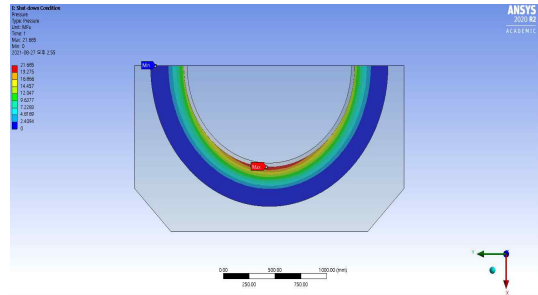

Fig. 11. Shut-down condition (Max. press: 21.685 MPa)

Under normal operating condition and design conditions, the contact area changes and becomes localized. The maximum contact pressure also increases. For the normal operating condition, due to thermal expansion the contact pressure concentrated toward outside. Even the sliding base has low friction coefficient, the RCS posture changes slightly and that causes this uneven contact pressure.

For design condition, it was assumed that entire structure is heated up to design temperature which causes greater thermal expansion of RCS and produces higher contact pressure as shown in Fig. 13.

In addition, there is a difference in the weight of water according to temperature and pressure, so this also had an effect.

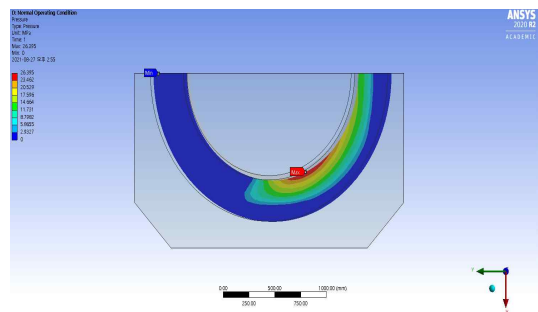

Fig. 12. Normal operating condition (Max. pres.: 26.395 MPa)

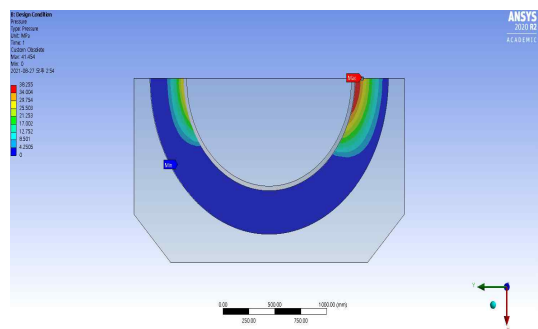

Fig. 13. Design condition (Max. press.: 38.255 MPa)

### **3. Conclusion**

In this study, we investigated SG support behavior for different loading condition, i.e. installed condition, shut-down condition, design condition and normal operating condition.

In order to analyze the contact status of SG, the whole RCS was modeled taking into account symmetry of geometry and loading condition. FEM meshed model was developed for the RCS quarter model based on hexahedral elements. The analysis was performed and the finding are as follows,

1. The contact surface pressure of SG support skirt contact surface to sliding base is not uniform.
2. The distribution of contact pressure depends on the state of SG operation.
3. There are very high contact pressure region appears indicating development of very high localized contact stress.
4. It is also observed that there are movement of SG support skirt. This movement should be taken account in the installation of SG during site installation of RCS.
5. Using the developed modeling and this study, we think that displacement analysis of SG should be performed in the future.
6. In order to alleviate the localized contact pressure, due to deformation of SG support skirt, redesign and optimization of SG support skirt may be necessary.

No accident condition was considered since SG support experiences very low stress compare to allowable stress intensity of 184 MPa and maximum yield stress of 345 MPa of SA-508 and cannot cause any failure before the failure of other part of RCS components. However, a further study on earthquake loading may needed to assess full scope of SG support skirt behavior. A consideration of seismic load on SG support skirt is beyond the scope this study due to a full RCS model is required for such case. It is recommended as future research.

### **REFERENCES**

- [1] Seungkyum Kim and Ihn Namgung, Development of APR1400 RCS 3D FEM Model and Assessment of Residual Stress due to the Change of Operational State, Korean Society of Mechanical Engineers, Reliability Division Spring Conference, pp. 163, 2021.
- [2] KHNP, APR1400 SSAR, Ch. 3. Design of Structures, Components, Equipment, and Systems, 2002.
- [3] ASME Boiler and Pressure Vessel Code, American Society of Mechanical Engineers, 2017 Ed.
- [4] Sang Quy Mai and Ihn Namgung, Design Verification of Re-engineered APR1400 SG Support According to ASME Code Section III-NB and NF, The Korean Society of Mechanical Engineers, Spring and Autumn Conference, pp. 1907-1912, 2017.