

## A Conceptual Design of Light-weighted Mobile Robot for the Integrity of SG Tubes in NPP

Yongchil Seo<sup>a\*</sup>, Kyungmin Jeong<sup>a</sup>, Hochul Shin<sup>a</sup>, Sung-uk Lee<sup>a</sup>, Jaewan Cho<sup>a</sup>, Youngsoo Choi<sup>a</sup>, Seungho Kim<sup>a</sup>,  
Chun Sup Shin<sup>b</sup>, Ki Tae Park<sup>b</sup>

<sup>a</sup>Fusion Technology Div., Korea Atomic Energy Research Institute, 1045 Daedeokdaero, Yuseong, Daejeon, 305-353

<sup>b</sup>Nuclear Power Technology Service Center, Korea Plant Service& Engineering, 216 GO-Ri, Jangan, Gijang, Busan, 619-711

\*Corresponding author: ycseo@kaeri.re.kr

### 1. Introduction

Steam generators (SG) are among the most critical components of pressurized water Nuclear Power Plants (NPP). SG tubes must provide a reliable pressure boundary between the primary and secondary cooling water. It is because that any leakage from tube defects could result in the release of radioactivity to the environment. Thus degradations of steam generator tubes should be monitored and inspected periodically under nuclear regulatory. In-service inspections of SG tubes are carried out using eddy current test (ECT) and the defected tubes are usually plugged. Because the radioactivity in the internal of SG chambers limits free access of human worker, remote manipulators are required.

In South Korea, Manipulators such as the Zetec SM series and the Westinghouse ROSA series have been used. Such manipulators are rigidly mounted to manways or tube sheets of SG. Confusions for the inspected tubes may occur from deflection of the manipulators. To reduce the deflections of the manipulators for covering the large working areas of tube sheets, sufficient rigidity is required and it leads to the increase of the weight. Such weight increase results in some difficulties for handling and more radiation exposure of human workers.

Recently light-weighted mobile robots have been introduced by Westinghouse and Zetec. The robots can move keeping in contact with the tube sheets using devices which are commonly called cam-locks. They are easier to handle and provide no confusion for the position of the inspected tubes. But when the clamping forces are loosed accidentally, they can be fall down and light repair works can be performed.

This paper provides the design results for a light-weighted mobile robot which is recently being developed in cooperation of our institutes.

### 2. Design of Mobile Robot

Our designs are mainly for the SG of OPR100 and ARP1400 of which the arrangement of tubes is triangular and the pitch between tubes is 1 inch. Two types are considered for our development. Fig.1 shows the first conceptual design model. It can be attached to the tube sheets by inserting its fingers and expanding

the outside of the fingers with cam-lock mechanisms. Two pairs of fingers are provided and each pair of fingers can be rotated independently to each other. By using the rotation the robot turns in a 60 degree step. It also has a linear guide to move in linear trajectories..

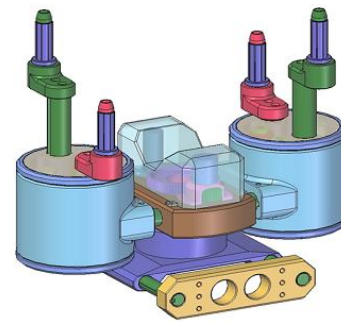
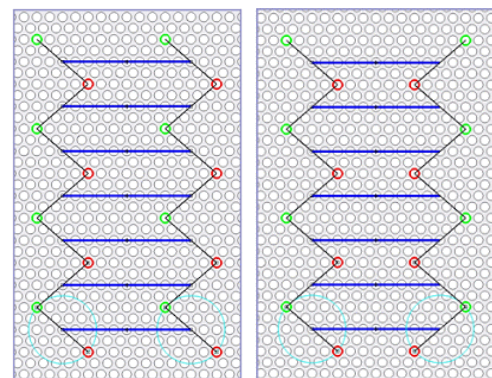

Fig. 1. Conceptual design model of type #1

Fig. 2 shows several motion patterns for linear motions. The red circles indicate the red-colored fingers and the green circles indicate the green-colored fingers. The blue lines correspond to the linear guides. Fig. 3 shows a turning pattern to change its orientation. More than two fingers are secured to tube sheets to prevent it from the accidental falling down.



(a)

(b)

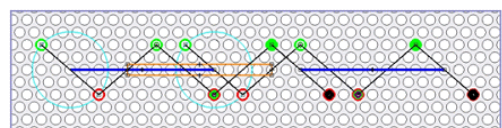

(c)

Fig. 2. Linear motion patterns for type #1

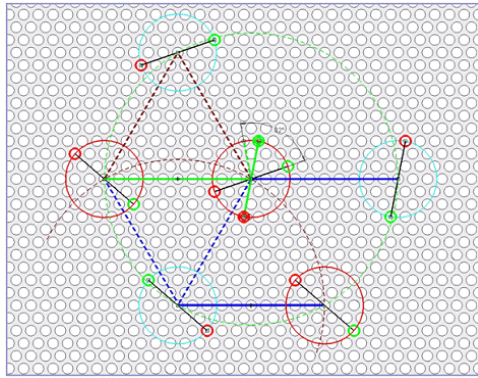

Fig. 3. Turning motion pattern for type #1

As shown in Fig.2, another conceptual design is considered to cope with the unbalancing effects during the change the clamping cam-lock in order to turn its orientation. The central clamping module has six fingers and provides rotational and up-down motions. The two out-sid-ed camping modules have only a rotationally driving axis. Its clamping mechanism is unique in that four or six fingers can be shrunk toward their center to simplify clamping mechanism. Because the central clamping module or two out-sid-ed modules is clamped to the tube sheets, the weight force is always in the clamping area and the unbalancing problem can be avoided. The motion patterns for linear or rotational motions are similar to that of the type #1.

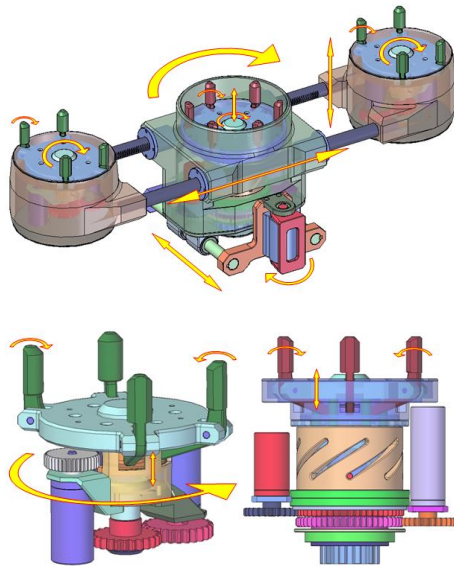

Fig. 4. Conceptual design model of type #2

Human workers can be exposed to relatively large radiation during the installation of light-weighted mobile robot to the tube sheets. In order to mount a installation clip to the tube sheet before the robot installation, human workers bring their arms into the man-way and it is relatively time consuming procedure.

We have designed an installation-assisting equipment as shown in Fig. 5. It is designed to be mounted to the upper portion of the man-way and the end point can be inserted into a tube. The basket holding a robot can slide into the SG chamber following the arctic guide. This equipment can be used for tooling changing.

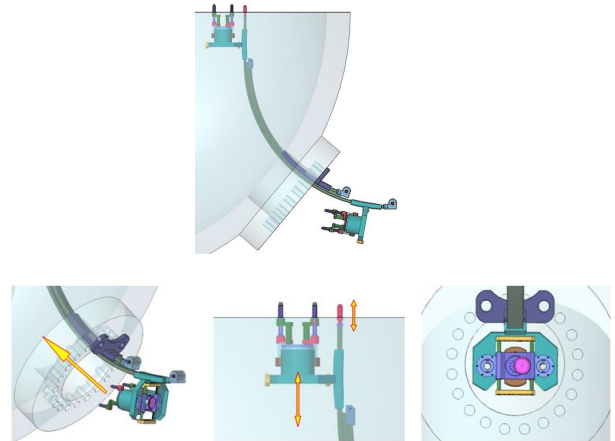

Fig. 5. Installation assisting equipment

### 3. Conclusions

We are developing a light-weighted mobile robot for inspection and plugging of SG tubes in NPP. We have considered two types of mobile mechanism. Installation assistance equipment is proposed to reduce radiation exposure and installation and tear-out time consumption. More detailed design and basic experiments are being progressed.

### Acknowledgement

The research described in this paper is being supported by the national project for the innovation of nuclear technology funded by the Ministry of Knowledge and Economics in South Korea.

### REFERENCES

- [1] H. Shin, K. Jeong, S. Jung and S. Kim, "Development of A Steam Generator Tube Inspection Robot with a Supporting Leg," Nuclear Engineering and Technology, Vol.41, p. 125, 2009.
- [2] L. Obrutsky, J. Renaud and R. Lakhani, "Steam Generator Inspections: Faster, Cheaper and Better, Are We There Yet?," IV Conferencia Panamericana de END Buenos Aires – Octubre 2007.
- [3] L. P. Houssay, Robotics and Radiation Hardening in the Nuclear Industry, Master thesis, Grad. School of the U. of Florida, 2000.
- [4] A. Iborra, B. Alvarea, C. Fernandez, J. M. F. Merono, Robots in Radioactive Environment, IEEE Robotics & Automation Magazine, p. 12, 2003.
- [5] www.westinghouse.com
- [6] www.zetec.com